

*Skylighting for the Northeast*

Skylighting and Lighting Quality  
 Sample Retail Layouts  
 Skylight and Controls Specifications



RETAIL SKYLIGHTING

knowhow

**INTRODUCTION**

Daylight is a powerful addition to a retail environment. It can dramatically enhance your store's appearance, attracting and retaining

shoppers. It may add to your profits with increased sales, and can certainly be designed to reduce your operating costs. This win-win approach to retail lighting provides you with better daytime lighting quality and higher light levels, while saving 30-50% of lighting energy costs.

This guide suggests how to design an energy efficient skylighting system for retail

environments. It provides sample retail layouts, skylighting rules of thumb, tips on how to integrate skylights with electric lighting, and lighting control strategies for maximum energy savings in the Northeastern U.S. It also discusses common skylighting specification issues, with

suggestions to maximize the value of your skylighting system.

**Daylighting Increases Sales**

A 1998 study looked at 18-month average gross sales for one chain retailer with skylights at 2/3 of its sites. All other things being equal, the stores with skylighting were found to sell 40% more than the equivalent non-skylit stores. This remarkable finding may be at the high end of a "daylighting effect," but it does show the powerful influence of daylight on sales.

**Most Stores Can Be Skylit**

Any single story retail space has the potential to be skylit. Two story spaces can skylight the top floor. Skylighting works well with the high, open ceilings of "big-box" retailers, as well as the lower, dropped ceilings of grocery stores and smaller buildings. Even boutique stores have been successfully skylit.



"We value the use of skylights in our stores and think daylighting makes a difference."

*Energy Manager,  
 Large Wholesaler*



Photo by Charles Michal

**In this grocery store, skylighting provides high illumination, superior lighting quality, and net energy savings**

**Turn Off The Lights!**

Skylighting systems save dollars by using photocontrols to automatically turn off the electric lights when interior daylight levels are high. This reduces both lighting and cooling costs, since reduced electric lighting cuts cooling loads. Daylight is inherently more efficient than electric light, contributing substantially less heat to a space for the same amount of light. Heating costs will increase slightly, because of less heat from the lights, but lighting and cooling savings are generally 2 to 10 times greater, depending on your location, building design and operation. An optimized skylighting system in the Northeast should result in net annual energy savings from about \$0.10 to \$0.30 per year for each square foot of daylit floor area (based on average fuel costs in 2000).

**QUALITY ISSUES FOR RETAIL SKYLIGHTING**

● **Use diffusing skylights**

Diffuse daylight is more efficient and prevents glare from sunspots or hotspots on merchandise

● **Distribute skylights uniformly**

A rule of thumb is the spacing of skylight should be less than 1.5 times the ceiling height

● **Turn off the electric lights!**

Use automatic photocontrols to dim or turn off lights when interior daylight levels are high

● **Select skylights with maximum light transmission and a moderate U value**

More light per unit of skylight glazing is better, reduction in heat loss & gain is secondary

● **Paint ceilings white**

Paint the ceiling and all structural elements white, also use a light colored floor materials

## Control Strategies

The choice of control strategy for the electric lighting is key to how much energy will be saved from a skylighting system. It also influences occupants' satisfaction.

### Switching

Automatic switching systems can be used in most retail spaces. Since people are actively moving about, they do not tend to notice subtle changes in light levels. Using at least three switching increments minimizes awareness of light level changes. The best switching systems control multiple lamps within a single fixture, so that lighting uniformity is always maintained.

### Dimming

Dimming controls are considered the high-end of photocontrol systems. They reduce lighting levels gradually, and thus are rarely noticeable. They can also provide the best energy savings in locations where there are frequent hourly variations in cloudiness. However, since dimming systems require more expensive dimming ballasts, their cost effectiveness must be carefully evaluated.

### Photosensor Location

The majority of retail skylighting systems place the photosensor directly in the skylight well. These "open loop" systems, which sense only the daylight levels, are reliable, relatively inexpensive, easy to install and calibrate.

# skylighting design:

Good skylighting design follows the same principles as good electric lighting design. It should help to focus the customer's attention on the merchandise and avoid causing visual discomfort.

Daylight is especially attractive to merchandisers since it provides the best color rendition of any light source. Under this high quality light, products look more natural, colorful and vivid. Also, good skylighting design can provide higher daytime illumination levels than electric lighting, while still meeting current energy codes. Customers notice that it is easier to examine products under daylight.

### Customer Perception

Most customers do not notice if a store has skylights or not. Of 45 customers interviewed at a chain store with skylights, only three were aware of the skylights. But they all had a favorable impression of the store, and typically commented that it seemed "more spacious," "cleaner," and "comfortable." Some retailers feel a need to keep the electric lights on to show that "we're open for business." This can defeat the daylight savings. A compromise is to leave one lamp in each fixture turned on. Customers will see the lights are on, and light levels will be fine because of the daylighting.

Skylights are an excellent way to provide uniform ambient lighting, but skylighting can also be used more strategically. Concentrating the daylight in certain parts of a store, such as along a circulation path, can create interesting variation. Skylights can also be placed along walls to create excellent wall-washing effects.

Electric lighting should be designed to complement the daylight, and of course to provide good night time illumination. It is important to ensure that the electric lighting is circuited for effective automatic photocontrol operation.

### Uniformity

Skylights should be treated more as light fixtures than as an architectural statement. Lots of smaller skylights, evenly spaced, will provide better and more efficient illumination than one monumental skylight. A good rule of thumb is that skylights should be evenly spaced at 1.0 to 1.5 times the ceiling height. Thus, the higher the ceiling, fewer and larger skylights can be used.

### Diffusion

Uniformity is also achieved by diffusion. Skylights take advantage of the power of sunlight, but need to diffuse the sunlight widely for efficiency. Most plastic glazing materials

## Estimating Energy Savings Using SkyCalc™

The value of energy savings from a skylighting design is a function of many factors, including building design and operation, local energy costs, and local climate conditions. In order to facilitate this complex calculation, and to help designers optimize their design, a simple spreadsheet tool, SkyCalc, has been developed. SkyCalc uses hourly weather data and a simple description of a building to estimate average daylight illumination levels and net energy savings from a given skylight design. SkyCalc has been used to generate the estimates in this knowhow guide. It is simple to use and can be downloaded for free from [www.h-m-g.com](http://www.h-m-g.com)

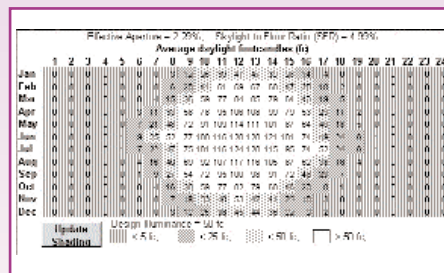

### SkyCalc Illumination Plot

This illumination plot shows the average footcandles that can be expected from a given skylight design, by hour and month of the year. Un-shaded hours indicate "full daylight saturation," when daylight illumination levels will typically exceed the target light level selected for the space. The shaded areas are those hours when partial electric lighting will be needed.

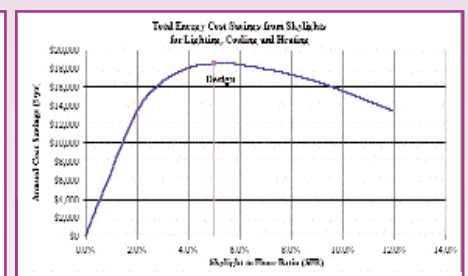

### SkyCalc Cost Savings Graph

For a given design, SkyCalc plots net building energy savings as a function of the percentage of roof area devoted to skylights (SFR). This graph allows the designer to quickly see how much skylight area is needed to optimize the energy performance of the building. All of the inputs to SkyCalc influence this curve. In general, a well designed skylight system will show optimum performance between 3% to 8% of roof area.

# quality and efficiency

used for skylights provide some diffusion, but some do it better than others (see discussion on page 7).

Diffusion can be enhanced by bouncing the light off light-colored skylight-wells, using baffles, or secondary refracting panels. Placing a refractive acrylic panel in a skylight well can provide good diffusion from a transparent skylight above.

## Light Transmittance

After diffusion, the second most important property of a skylight glazing material is the visible transmittance (Tvis), which tells how much light passes through the glazing material. The more light, the better. Skylights with the highest possible visible light transmittance perform best throughout the country. A good rule of thumb is to select a skylight with at least a 70% visible light transmittance. Select a glazing material that does not yellow or suffer degradation for at least 10 years.

## Solar Heat Gain

A third important property is the Solar Heat Gain Coefficient (SHGC), or how much solar heat passes through the skylight. A high ratio of visible transmittance to solar heat gain will increase lighting savings while reducing net cooling loads.

## U-factor

Because most commercial buildings are self-heating much of the year, and because heating fuels are generally less expensive than the electricity used for lighting, insulating value is usually the least important property of a skylight. In order to reduce heat loss (and heat gain), the most effective strategy is generally to reduce the required size of the skylight by increasing the visible light transmittance of the glazing material, so that there is less heat loss per unit of useful daylight.

## Light Well Design

The geometry of the skylight well provides opportunities for both diffusion and glare prevention. A "cut-off" angle defines the visual angle at which an observer cannot see the bright glazing material. Reducing the brightness of the light well surfaces relative to the ceiling surfaces improves the visual comfort of the design.

### Wide



A shallow light well with a wide cut-off angle allows the widest distribution of light, but will not prevent view of the skylight. Best used only in very high ceilings or combined with some baffling.

### Narrow

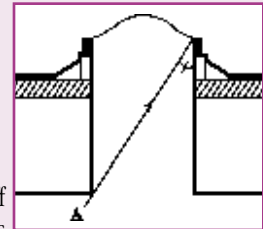

A deep light well with a narrow cut-off angle prevents glare from direct view of the skylight. However, it also concentrates the daylight into a smaller area, reducing efficiency.

### Splayed

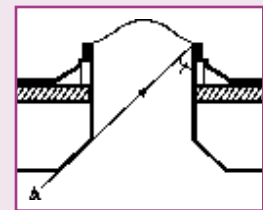

This design achieves a 45 degree cut-off angle, acceptable in most conditions. The lower, splayed surfaces will have about the same brightness as the ceiling, greatly increasing visual comfort.

Paint ceiling and all upper elements white

Use structural elements to help diffuse light



Use light-colored flooring materials

Uniform high levels of illumination on products

## Prevent Glare

- **Keep skylight glazing out of sight**  
Use the structural system, deeper light wells, baffles, or decorative banners to help shield the view of the skylight.
- **Use white ceiling materials**  
Use white surfaces at the ceiling to reduce visual contrast with the brighter skylights.
- **Use light colored, low-gloss flooring**  
Avoid highly polished surfaces, which can create glaring reflections of the skylights.
- **Do not allow direct sun in**  
Raw sunlight is too bright. Diffuse it over a large area.



"We chose to go with skylighting for the sheer beauty of a daylit space. The photocontrols provide the energy savings that sweeten the deal."

Architect/Retail Designer - Boston, MA

## Use High Transmission Glazing

Clear prismatic skylights can show better energy performance than white diffusing skylights in all US climates. The chart is for a retail store in New York City.

Glazing Type (double glazed)	Tvis	SHGC	U-factor	Lighting savings	Net energy savings
Prismatic Clear Acrylic	74%	67%	0.97	45%	\$0.30/SF*
Diffusing White Acrylic	39%	30%	0.97	36%	\$0.24/SF*

\* Annual cost savings per square foot of skylit space

# skylit retail layouts

Daylight Makes a Difference!



Photo by Ed Asmus

White floors and ceiling, combined with the splayed wells of the skylights, provide a clean, spacious appearance. No electric lights are on in photo, but over 100 fc were measured on products.

## COMPARISON CHART FOR DIFFERENT RETAIL

	Layout 1		La
Skylight Design	finished ceiling		rai
Ceiling/Mounting Height	14'/14'		22
Electric Lights	recessed linear fluorescent 50 fc		pe 50
Power Density	1.45 w/sf	1.45 w/sf	1.4
Control Strategy	switch by lamp	dimming ballasts	sw lan
Light Savings	~35%	~39%	~3
Appearance	****	****	**
Light Quality	****	****	**
Lighting Cost Upgrade	30-50%	50-70%	5-1
<b>OVERALL VALUE</b>	<b>***</b>	<b>**</b>	<b>**</b>

### Provisos:

1. The discussions and graphics in this guide have been generalized and greatly simplified in order to help a designer and electric engineer to integrate these general concepts with the specifics of your building and site.
2. Projections of energy savings are based on SkyCalc analysis using typical weather data, average year-round weather, and average energy prices. Actual savings will obviously vary according to actual design, building operation, weather, and energy prices.

## retail layout 1 - finished ceiling

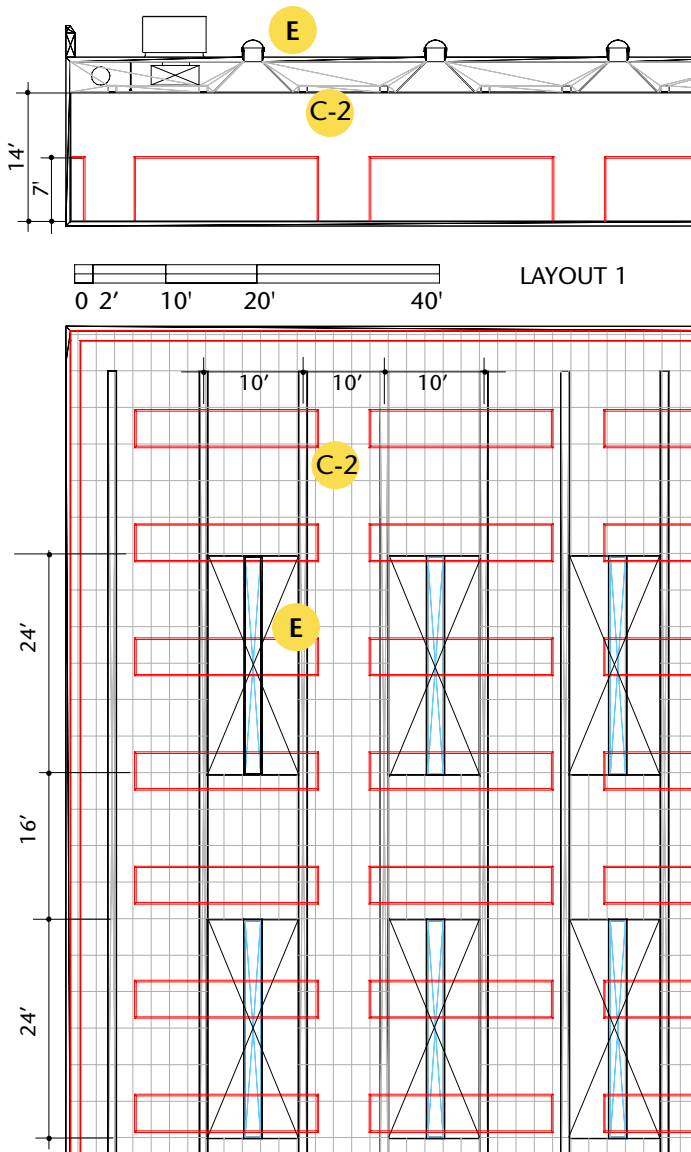

This design features a finished ceiling throughout, which gives it a more refined look. Linear skylights are recessed into deep wells, with a secondary diffuser in the throat of the well. Linear two-lamp fluorescent fixtures are recessed into either side of the skylight well.

Double glazed, high transmission (74%), diffusing skylights allow for maximum daylight in the space while minimizing the area required for skylights. This layout shows a 6% skylight to floor area ratio (SFR) using 2' x 24' barrel or ridged shape skylights on a 40' x 20' grid.

The deep, splayed wells with an extra diffuser create exceptionally low glare and uniform daylighting conditions. A very light-colored flooring material helps to reflect light back on to the ceiling, equalizing brightness between the horizontal ceiling and the sloped skylight well walls. The steeper the slope of the well walls, the brighter the surfaces will be.

### Lighting Control Strategy

Either automatic switching or dimming controls can be used. With switching, one and then two lamps are switched off when daylight illumination reaches approximately 50% and 100% of target electric illumination levels. Since the fixtures are recessed, and directly under the bright light wells, it is not easy to notice whether they are on or off during the day. Dimming controls will be more expensive, but may also provide greater savings.

### Energy Savings Analysis

6.0% SFR	Switching		Dimming	
	Light savings	Savings* per SF	Light savings	Savings* per SF
NYC	37%	\$0.29	40%	\$0.30
Buffalo	35%	\$0.25	39%	\$0.27
Boston	35%	\$0.19	38%	\$0.19

\* Annual cost savings per square foot of skylit space

## LAYOUTS

### Layout 2

raised center ceiling  
 24'/14'  
 recessed linear fluorescent  
 30 fc  
 1.45 w/sf  
 switched by  
 dimming  
 ballasts  
 ~45%  
 \*\*\*  
 \*\*\*\*  
 20-30%  
 \*\*\*

### Layout 3

open ceiling  
 24'/15'  
 low bay MH  
 30 fc  
 0.91 w/sf  
 switched by  
 fixture  
 ~29%  
 \*  
 \*\*  
 basis  
 \*\*\*

low bay CFL  
 30 fc  
 0.94 w/sf  
 switched by  
 lamp  
 ~42%  
 \*\*  
 \*\*\*  
 5-10%  
 \*\*\*\*

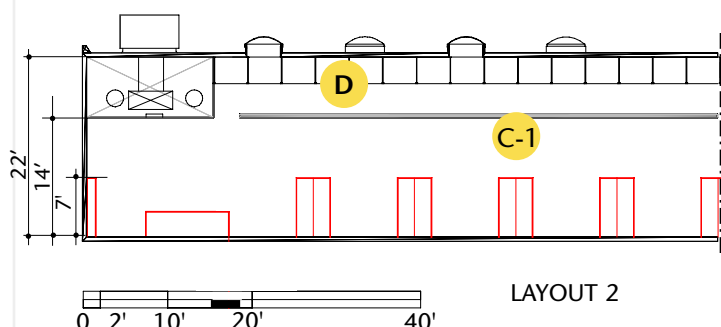

Photo by L. Hesong

A raised ceiling pulls customers into the skylit center of this grocery. A conventional dropped ceiling rings the perimeter.

present useful advice in this condensed format. Consult with your architect, lighting designer to refine the details. 2000 energy prices, and various design and operation assumptions for each example. prices.

## retail layout 2 - raised center ceiling



LAYOUT 2

This intermediate design combines a lower, dropped ceiling at the perimeter of the store and a raised ceiling in the center. Linear fluorescent lighting is mounted perpendicular to the shelving throughout, recessed at the perimeter and pendant under the skylights, creating a uniform ceiling appearance. HVAC ducts are recessed in the dropped ceiling at the perimeter. Diffusing, high-transmission skylights on a regular grid light the center of the store, creating high daytime illumination levels in the central area. At the outer walls, electric lighting only provides lower ambient levels, allowing the more efficient use of valance lighting and local spot lighting to highlight selected products.

### Lighting Control Strategy

Multi-lamp linear fluorescent lighting suggests two control options: step switching or dimming.

**Switching:** Two of the three T-8 lamps in the linear fixtures are switched off when daylight illumination reaches approximately 1/3 and 2/3 of the target electric lighting levels. The middle lamp is always left on to maintain uniformity of appearance between the ceilings of the daylight and non-daylit areas. For greatest efficiency, four lamps per ballast is recommended.

**Dimming:** A dimming system could use either T-8 or T-5 lamps, with any number of lamps per fixture. Lower output fixtures could be spaced closer together. Two control zones are suggested: one directly under the skylights, and a second for the first one or two rows of luminaires in the dropped ceiling where daylight will spill over.

### Energy Savings Analysis

6.0% SFR	Switching		Dimming	
	Light savings	Savings per SF	Light savings	Savings per SF
NYC	36%	\$0.21	45%	\$0.30
Buffalo	36%	\$0.19	45%	\$0.27
Boston	35%	\$0.11	44%	\$0.18

\* Annual cost savings per square foot of skylit space



Skylights provide uniform illumination and add highlights in this wholesale store. Note the white ceiling.

### Control Diagram

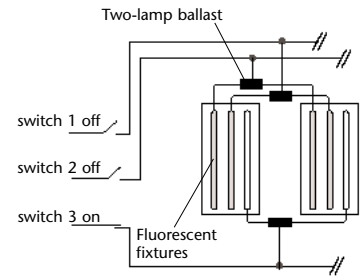

#### Tandem Wiring for Fluorescent Multi-Lamp Switching

This schematic wiring diagram shows how lamps can be individually switched in a three-lamp fixture, allowing three levels of light output. This diagram is for two-lamp ballasts, here connecting two fixtures. The same principle applies to four-lamp ballasts, where one ballast could power one lamp each in four adjoining fixtures.

## retail layout 3- open ceiling

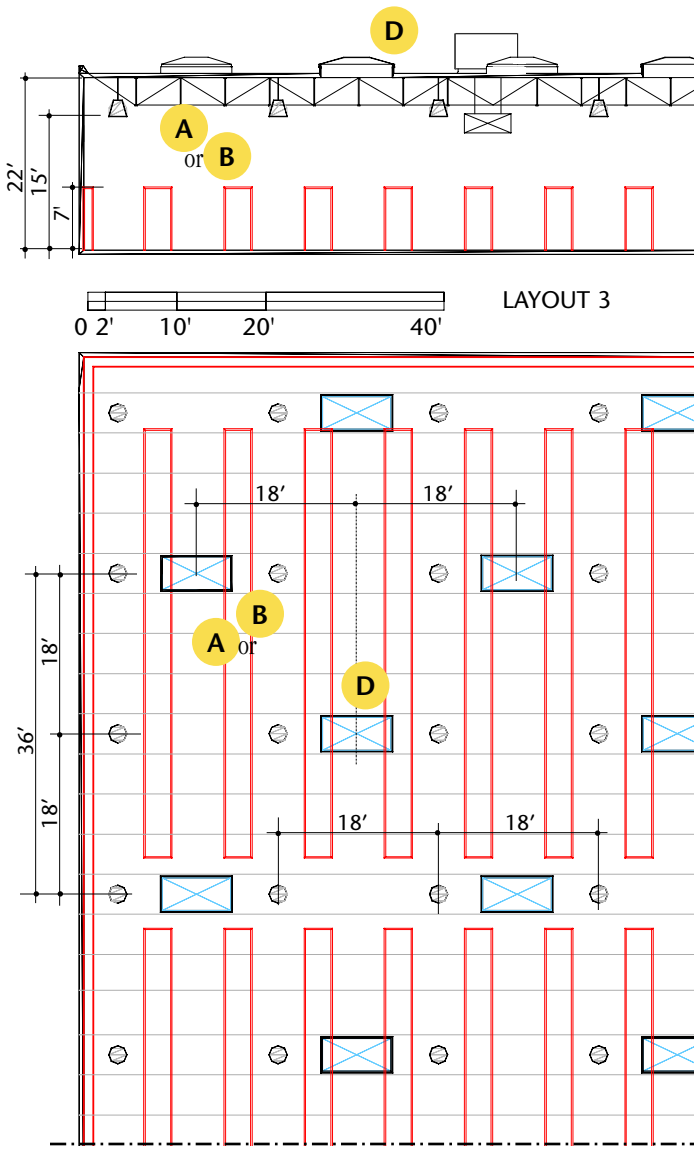

This design assumes exposed structural, mechanical, and electrical systems. Low bay lighting fixtures are on a regular grid. Skylights are located in every other square of the lighting grid in a checkerboard pattern.

Two options are considered: Metal halide and compact fluorescent lamps. While more expensive initially, compact fluorescent low bay fixtures have a number of important advantages over metal halide in retail applications: 1.) They can be switched at multiple levels within a fixture, maintaining uniformity of illumination and efficiency levels. 2.) There is no re-strike time, allowing tighter switching control and thus, greater energy savings. 3.) There is no perceptible color shift. 4.) Lamps can be controlled to maintain uniform life, reducing maintenance costs.

#### Lighting Control Strategy

**Metal halide:** An effective solution is to switch 2/3 of the fixtures fully on-off in response to daylight levels. Because metal halide lamps generally require a re-strike time of 5 to 10 minutes, it is recommended that switching occurs at a daylight illumination at least 10 footcandles above 1/3 and 2/3 of the target electric illumination level. Also, to ensure safety at all times, 1/3 of the fixtures, preferably those that illuminate the perimeter of the store, are always left on during occupied hours.

**Compact Fluorescent:** Low bay fixtures with multiple compact fluorescent lamps allow multiple levels of illumination from each fixture, maintaining greater visual uniformity. Three, four, or even more, levels of switching are possible. Programmable controllers can vary which lamp is turned off first, equalizing lamp life.

#### Energy Savings Analysis

4.0% SFR	Metal Halide 2/3 switching		Compact FL 3/3 switching	
	Light savings	Savings* per SF	Light savings	Savings* per SF
NYC	30%	\$0.10	43%	\$0.17
Buffalo	29%	\$0.07	42%	\$0.15
Boston	28%	\$0.04	41%	\$0.09

\* Annual cost savings per square foot of skylit space.

# skylights and lighting fixture schedule

These highly abbreviated lamp and fixture descriptions are keyed to retail layouts. Choose lamps which match daylight color (4100°K to 5000°K), and have longest life and highest lumen output per watt.

## A. LOW BAY PRISMATIC METAL HALIDE - Pendant

LAMPS: (1) 250 W Metal halide.

DESCRIPTION: Open prismatic glass refractor housing. 15% uplight component. Field adjust lamp position for widest light distribution. 265 nominal input watts.

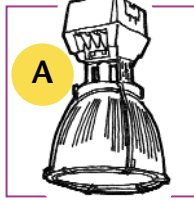

## B. LOW BAY PRISMATIC COMPACT FLUORESCENT

LAMPS: (9) 36W twin tube; 3-lamp electronic ballasts.

DESCRIPTION: Open prismatic acrylic refractor housing. Lamps in radial pattern. Switch lamps separately. 15% uplight component. 305 nominal watts.

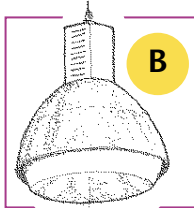

## C. FLUORESCENT INDUSTRIAL STRIP WITH REFLECTOR

LAMPS: 32W T8; 4-lamp electronic ballasts.

DESCRIPTION: Strip luminaire with reflector. 35 degree shielding. 90% minimum fixture efficiency. Control each lamp individually (or alternate: use dimming ballasts).

**C-1** = 3 lamps across, pendant. Maximum 10% uplight. 93 nominal input watts.

**C-2** = 2 lamps across, recessed. 62 nominal input watts.

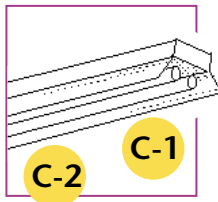

## SKYLIGHT SPECIFICATIONS

Double-glazed, non-venting plastic unit skylights with condensate gutter attached to integral, insulating frame.

**SHAPE:** For Layout 1 (finished ceiling pattern), choose **(E)** linear ridge or barrel vault. For Layout 2 or 3 choose **(D)** bubble, double arched or pyramid shape.

**GLAZING MATERIAL:** Choose highest light transmittance available. 70%+ visible light transmittance is recommended.

**DIFFUSION:** Choose the most diffusing material available. There is currently no precise language that can be used to specify good diffusion, thus diffusion is best assessed by direct visual inspection. For example, sunlight passing through the diffusing glazing material should not concentrate the light into local hot spots, nor cast a discernable shadow from a hand held three feet above the ground. Like wise an image should not be discernable through the glazing.

**ADDITIONAL DIFFUSER:** For Layout 1 add a clear, refracting lens in the throat of the skylight well. Prismatic acrylic lenses used for lighting fixtures can perform very well. Choose sufficient thickness to prevent any future sag across span. Hinge diffuser to allow for cleaning and maintenance.

For layouts 2 and 3: If high light transmission, fully diffusing skylights are not available locally, then select clear, non-diffusing skylights and add secondary diffuser to well.

**HEAT GAIN AND LOSS:** Solar Heat Gain Coefficient = 70% maximum. Unit U-factor = 1.0 maximum (including framing effects).

**UNIT SIZE:** Choose specific unit dimensions via SkyCalc™ to optimize energy performance for a given layout pattern and skylight to floor area ratio (SFR).

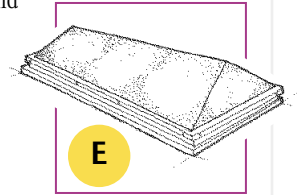
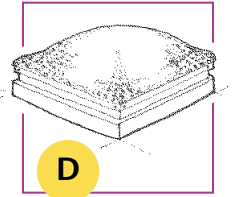

## LIGHTING CONTROL STRATEGIES

**PHOTOSENSOR LOCATION:** Place a photosensor that can read daylight illumination levels ranging from at least 100 to 10,000 footcandles in the throat of the skylight well, held off at least 12" from the side of the well. This is combined with an "open-loop" controller which only responds to daylight levels. The illuminance reading at the sensor will be a constant multiple of daylight illuminance at the floor level.

Choose a well location with representative daylight patterns, with no unusual shading from nearby equipment, trees, or structures. Alternatively, use an averaged signal from more than one sensor location.

**METAL HALIDE FIXTURE SWITCHING:** Fixtures are circuited in three groups: 1) those closest to the skylights 2) intermediate distance, and 3) farthest from skylights and/or along the perimeter of store. The first circuit should automatically switch off after daylight levels have exceeded 40% of electric target for five minutes or more. The second circuit turns off when daylight levels exceed electric target by 80%. The third circuit is always left on during occupied hours. A time delay of at least 10 minutes should be imposed before the lights can switch back on when daylight levels drop.

**FLUORESCENT MULTI-LAMP SWITCHING:** Lamps are automatically switched within each fixture, creating the potential for 33%, 66% or 100% of light output in response to daylight levels. If lamps are directly visible to occupants, leave 1/3 of lamps always on. If lamps are not visible to occupants, switch all lamps for greater savings. Switch lamps in increments that reduce illumination levels by no more than 1/3 per step. Allow a minimum of a five-minute time delay before switching on or off. (see Control Diagram on page 6).

**FLUORESCENT DIMMING:** It is a more expensive photocontrol option, but may also save the most energy, especially in climates with highly variable cloudiness conditions. Dimming down to 10% light output is appropriate and readily available. Specify a proportional controller that allows continuous adjustment of power output to signal input. Lamps operated under dimming ballasts should be operated at full power for their first 100 hours to ensure stable operation. Verify with manufacturers that lamps and dimming ballasts are compatible.

# construction issues

## Leakage

Modern unit skylights are far less prone to leaks than older, site-built skylights that caused many of the problems that building owners remember. Plastic molding techniques, factory-sealed gaskets, and precision metal frames have improved the performance of the available products dramatically. Select manufacturer's products with a proven track record of life-time leak resistance. Operable or venting skylights may be more likely to have leak failures. Today, the greatest area of concern is with installation details and practices. Careful detailing, and tight specifications that call for installation warranties from contractors, are the best protections against leaks.

## Condensation

Condensation will normally occur on the inner surface of a skylight at night as warm indoor air rises carrying moisture that condenses on the colder glazing and framing surfaces. Insulated frames and double or triple glazed skylights will reduce, but not prevent this condensation. Water marks from condensation drips are commonly mistaken for skylight leaks. The best solution is a "condensation gutter" mounted at the bottom of the skylight, which is sized to collect the maximum amount of condensate at night and allow it to re-evaporate during the day.



"I have 15 years experience building 200 stores with hundreds of skylights each. The skylights haven't presented a problem for leaks. We have systematized our design. The skylight curb and safety grate are constructed as an integral part of the building frame. The roofing specification requires a 25-year guarantee, which encourages careful attention to flashing and quality control."

*Construction Manager, Large Wholesaler*

## Skylight Components

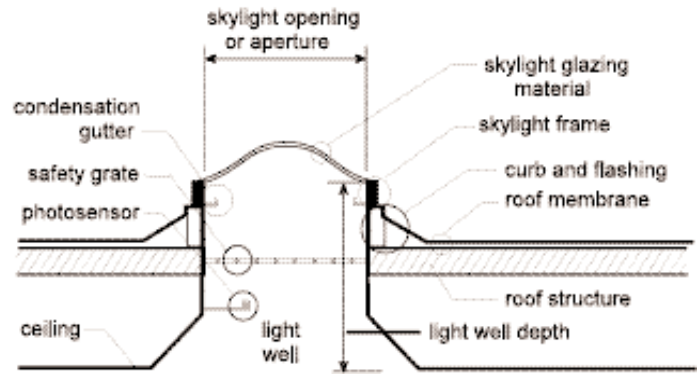

## Safety and Security

Retailers are justifiably concerned about the safety and security of using skylights in their buildings. To address safety and security concerns:

- Locate roof work areas and maintenance paths away from skylights
- Select glazing materials that are not easily shattered by heavy or sharp objects
- Install skylight units with tamper-proof screws
- Include a safety grate in the skylight well which can resist the fall of a heavy worker (300 lbs is often recommended)

The most common safety grate is a grid of steel bars spaced every six inches mounted inside to either the frame or the curb. This both protects people from accidental falls and prevents thieves from breaking in. Some manufacturers provide a safety grate as a factory built option for their units. Other building owners include it as a standard site-built specification item.

Underwriters Lab (UL) Standard 972 covers the strength of the glazing resisting the efforts of burglars, while American Society of Testing Methods (ASTM) Standard F588 tests how well the frame will hold up to "forced entry." To meet these standards one may be limited to specialty glazing materials and a heavy-duty frame.

**ACKNOWLEDGEMENTS** The *LIGHTING KNOWHOW* series was developed, funded, and sponsored by the following members of the DesignLights Consortium:



**New York State Energy Research and Development Authority (NYSERDA)**

**National Grid**

- Massachusetts Electric
- Narragansett Electric
- Granite State Electric
- Nantucket Electric

**NSTAR Electric**

**Unitil**

- Fitchburg Gas and Electric Light Company

**Northeast Energy Efficiency Partnerships, Inc.**

Additional support provided by the **American Architectural Manufacturers Association (AAMA)**

Content and graphics developed by Heschong Mahone Group, with support from Hayden McKay Lighting Design, Inc. and Weller & Michal Architects, Inc.

Graphic design by Heschong Mahone Group using templates from Outsource.

*For more information contact:*



# skylit retail layouts

Daylight Makes a Difference!



White floors and ceiling, combined with the splayed wells of the skylights, provide a clean, spacious appearance. No electric lights are on in photo, but over 100 fc were measured on products.

## COMPARISON CHART FOR DIFFERENT RETAIL LAYOUTS

	Layout 1		Layout 2		Layout 3	
Skylight Design	finished ceiling		raised center ceiling		open ceiling	
Ceiling/Mounting Height	14'/14'		22'/14'		24'/15'	
Electric Lights	recessed linear fluorescent 50 fc		pendant linear fluorescent 50 fc		low bay MH 30 fc	low bay CFL 30 fc
Power Density	1.45 w/sf	1.45 w/sf	1.45 w/sf	1.45 w/sf	0.91 w/sf	0.94 w/sf
Control Strategy	switch by lamp	dimming ballasts	switch by lamp	dimming ballasts	switch by fixture	switch by lamp
Light Savings	~35%	~39%	~36%	~45%	~29%	~42%
Appearance						
Light Quality						
Lighting Cost Upgrade	30-50%	50-70%	5-10%	20-30%	basis	5-10%
<b>OVERALL VALUE</b>						

**Provisos:**

- The discussions and graphics in this guide have been generalized and greatly simplified in order to present useful advice in this condensed format. Consult with your architect, lighting designer and electric engineer to integrate these general concepts with the specifics of your building and to refine the details.
- Projections of energy savings are based on SkyCalc analysis using typical weather data, average year 2000 energy prices, and various design and operation assumptions for each example. Actual savings will obviously vary according to actual design, building operation, weather, and energy prices.



A raised ceiling pulls customers into the skylit center of this grocery. A conventional dropped ceiling rings the perimeter.

## retail layout 1 - finished ceiling

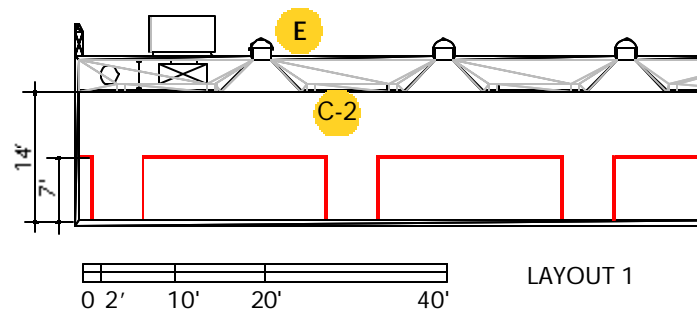

This design features a finished ceiling throughout, which gives it a more refined look. Linear skylights are recessed into deep wells, with a secondary diffuser in the throat of the well. Linear two-lamp fluorescent fixtures are recessed into either side of the skylight well.

Double glazed, high transmission (74%), diffusing skylights allow for maximum daylight in the space while minimizing the area required for skylights. This layout shows a 6% skylight to floor area ratio (SFR) using 2' x 24' barrel or ridged shape skylights on a 40' x 20' grid.

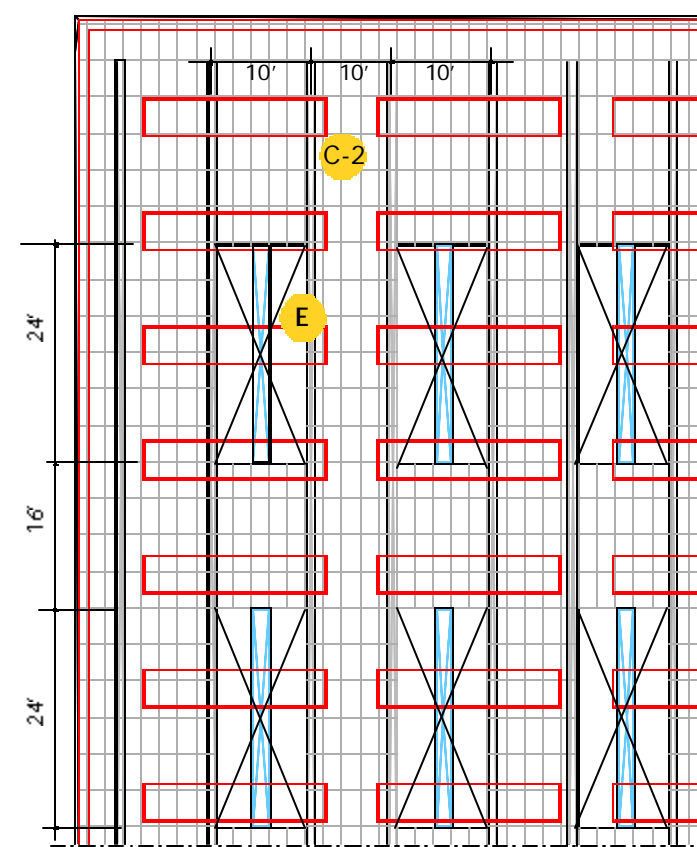

The deep, splayed wells with an extra diffuser create exceptionally low glare and uniform daylighting conditions. A very light-colored flooring material helps to reflect light back on to the ceiling, equalizing brightness between the horizontal ceiling and the sloped skylight well walls. The steeper the slope of the well walls, the brighter the surfaces will be.

**Lighting Control Strategy**

Either automatic switching or dimming controls can be used. With switching, one and then two lamps are switched off when daylight illumination reaches approximately 50% and 100% of target electric illumination levels. Since the fixtures are recessed, and directly under the bright light wells, it is not easy to notice whether they are on or off during the day. Dimming controls will be more expensive, but may also provide greater savings.

**Energy Savings Analysis**

6.0% SFR	Switching		Dimming	
	Light savings	Savings* per SF	Light savings	Savings* per SF
NYC	37%	\$0.29	40%	\$0.30
Buffalo	35%	\$0.25	39%	\$0.27
Boston	35%	\$0.19	38%	\$0.19

\* Annual cost savings per square foot of skylit space

## retail layout 2 - raised center ceiling

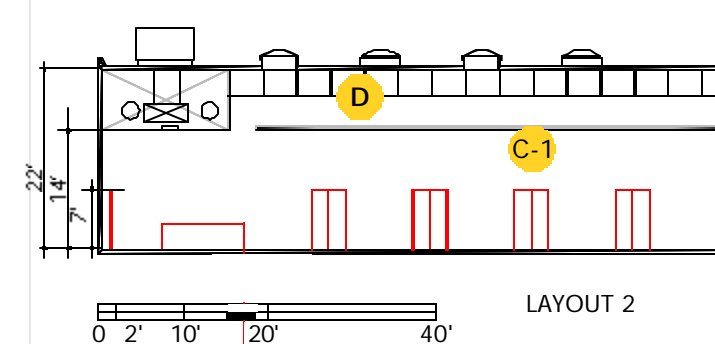

This intermediate design combines a lower, dropped ceiling at the perimeter of the store and a raised ceiling in the center. Linear fluorescent lighting is mounted perpendicular to the shelving throughout, recessed at the perimeter and pendant under the skylights, creating a uniform ceiling appearance. HVAC ducts are recessed in the dropped ceiling at the perimeter. Diffusing, high-transmission skylights on a regular grid light the center of the store, creating high daytime illumination levels in the central area. At the outer walls, electric lighting only provides lower ambient levels, allowing the more efficient use of valance lighting and local spot lighting to highlight selected products.

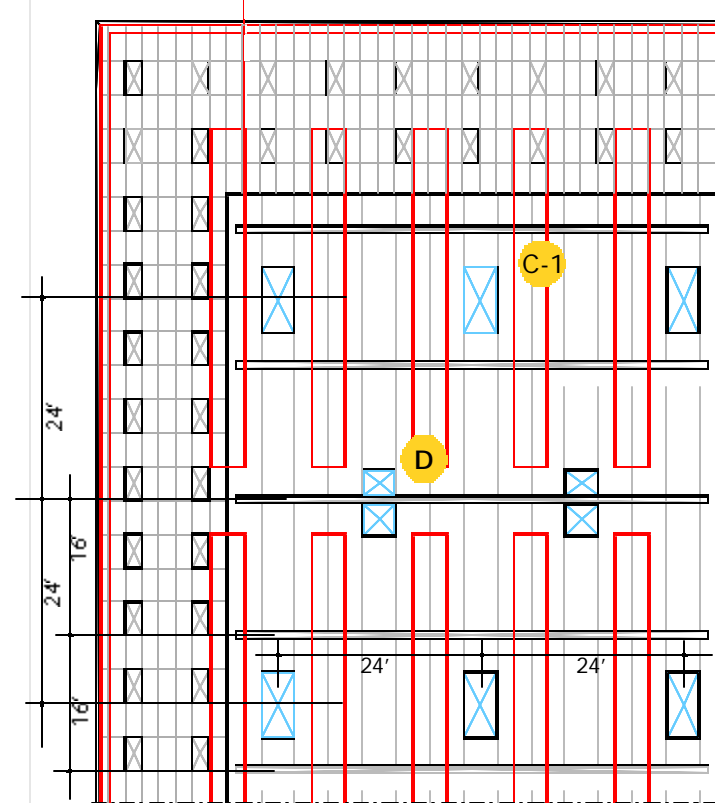

**Lighting Control Strategy**

Multi-lamp linear fluorescent lighting suggests two control options: step switching or dimming.

**Switching** Two of the three T-8 lamps in the linear fixtures are switched off when daylight illumination reaches approximately 1/3 and 2/3 of the target electric lighting levels. The middle lamp is always left on to maintain uniformity of appearance between the ceilings of the daylight and non-daylit areas. For greatest efficiency, four lamps per ballast is recommended.

**Dimming** A dimming system could use either T-8 or T-5 lamps, with any number of lamps per fixture. Lower output fixtures could be spaced closer together. Two control zones are suggested: one directly under the skylights, and a second for the first one or two rows of luminaires in the dropped ceiling where daylight will spill over.

**Energy Savings Analysis**

6.0% SFR	Switching		Dimming	
	Light savings	Savings per SF	Light savings	Savings per SF
NYC	36%	\$0.21	45%	\$0.30
Buffalo	36%	\$0.19	45%	\$0.27
Boston	35%	\$0.11	44%	\$0.18

\* Annual cost savings per square foot of skylit space