



Bringing Efficiency to LightSM

DesignLights Consortium[®] Manufacturer's Guide

May 10, 2019

Contents

I.	Latest Updates.....	8
I.	May 10, 2019 Version: Added guidance for delisting requests, manufacturer name updates, testing constraints, pre-equivalent housing requests, testing and reporting for modular products, tolerances, and driver spec sheet and ISTMT requirements. Updated the fields that are currently reported on the DLC QPL. Added clarification regarding acceptable payment methods, color tuning eligibility, multiple LEDs, testing and reporting requirements for linear replacement lamps, compatibility documentation for CFLEDs, requirements for IES files, and THD and Power Factor requirements.....	8
II.	March 29, 2019 Version: Added eligibility requirements and testing and reporting guidance for Field Adjustable Light Distribution (FALD) products. Updated Private Label application requirements to clarify the process for wholly owned subsidiaries wishing to use a different model number/brand than the Parent company. Removed requirement that spec sheets submitted for application review may not include the DLC logo. Updated language referencing IES LM-80 to IES LM-80-15.....	8
III.	March 6, 2019 Version: Family Grouping requirements revised to clarify that while products in the group must use identical LED packages, modules, or arrays, other design features and components are typically allowed to differ as long as the impact on performance is clear.	8
IV.	January 17, 2019 Version: ISTMT testing guidance updated to clarify the requirements for using a temporary hole to access the temperature measurement point. Clarified eligibility, testing, and reporting requirements for Type-C Linear Replacement Systems with non-identical lamps. Revised the PUD definitions for Outdoor Pole/Arm-Mounted Decorative Luminaires and Architectural Flood and Spot Luminaires.	8
V.	November 7, 2018 Version: Technical Requirements V4.4 released November 1, 2018. Technical Requirements Version 4.4 was released. Revised Primary Use definitions for Integrated Style and Linear Style Troffer Retrofit Kits. Revised Primary Use names for UL Type B and UL Type C Lamps. Added eligibility and testing requirements for field adjustable light output products and DC/PoE products.	8
VI.	June 12, 2018 Version: Technical Requirements V4.3 released March 26, 2018. Technical Requirements Version 4.3 has been released. Added Primary Use Designations and testing and reporting requirements for 3-foot and 8-foot Linear Replacement Lamps. Added 2G11 bases to eligible Four Pin-Base Replacement Lamps for CFLs. Updated the safety documentation requirements. Added testing	

and reporting requirements for field adjustable and color tunable products.
Updated Field Adjustable policy, and revised Private Label fees. Multiple LED
Policy revised to account for color tunable products..... 8

VII. February 22, 2018 Version: References to the LED Lighting Facts submission
requirement removed due to the closing of the LED Lighting Facts program. 8

VIII. January 10, 2018 Version: Requirements for evaluating Lumen Maintenance
using Option 2 revised. Logo Compliance Guidelines updated..... 8

IX. November 10, 2017 Version: Additional clarity provided regarding how DLC
evaluates IES files. 9

X. June 26, 2017 Version: Technical Requirements V4.2 released April 28, 2017
and Application Portal released. Technical Requirements Version 4.2 has been
released. Added Primary Use Designations for Linear Replacement Lamps, testing
and reporting requirements for Hazardous Location Lighting, Allowances for
products that have low CCT or high CRI. Application Portal for online submission
of QPL applications released with revised online process. Added guidance for
thermocouple attachment during the ISTMT..... 9

XI. November 4, 2016 Version: Technical Requirement V4.1 released October 28,
2016 and Policy Updates. Technical Requirements Version 4.1 has been released.
Added Primary Use Designations for Four Pin-Base Replacements for CFLs and U-
Bend replacement lamps. Policy updates include adoption of ANSI C78-277-2015,
Clarification on rated data requirements, and revisions on the Private
Label/Multiple Listing policy including requiring safety certification for Private
Label Applications. 9

XII. September 14, 2016 Version: Revised Definition of Architectural Flood and
Spot Luminaires and Logo Guidance. Added definition to include "Billboard
Lighting." Clarified logo use for general marketing materials and product specific
marketing materials. Redefined logo violation policy..... 9

XIII. June 10, 2016 Version: Technical Requirement V4.0 released June 1, 2016.
Minimum efficacy standards raised in each category. General application for
'Display Case Lighting' has been changed to 'Case Lighting'. Added guidance on
reporting Rf and Rg values. Updated Application forms to V4.0. 9

XIV. April 15, 2016 Version: Updates to Primary Use Definitions, Retrofit Kit Policy,
Family Grouping Policy, Private Label Agreement Form, Test Report Authorization
Form, and Logo and Trademark Use Guidelines 9

XV. December 14, 2015 Version: Technical Requirements V3.1..... 9

XVI. August 3, 2015 Version: Technical Requirements V3.0, Updates to Website
FAQs, and Logo and Trademark Use Guidelines 9

XVII. April 9, 2015 Version: Category Definitions	9
XVIII. July 18, 2014 Version: Category Definitions	10
XIX. July 8, 2014 Version: Dimming Information	10
XX. January 29, 2014 Version: LED Lighting Facts Information	10
XXI. October 22, 2013 Version: Lab Testing Requirements update	10
XXII. September 27, 2013 Version: Technical Requirements v2.1 updates.....	10
1. Primary Use Definitions	10
2. Retrofit Kits	10
3. Linear Replacement Lamps.....	10
4. LED Lighting Facts Information	10
XXIII. September 10, 2013 Version: LED Lighting Facts Information	11
II. Purpose	11
III. DesignLights Consortium Overview	11
I. About the DLC and the Commercial LED Luminaire Qualified Products List ...	11
II. Accepted Primary Uses	12
1. Primary Use Eligibility.....	12
2. The DLC and ENERGY STAR®	12
3. Primary Use Definitions	12
III. DLC Classifications.....	20
1. DLC Standard Classification.....	20
2. DLC Premium Classification	20
IV. Allowances	20
V. Tolerances.....	21
IV. Understanding Testing Principles.....	22
I. Photometric and Electric Testing (LM-79).....	22
II. Lumen Maintenance (ISTMT, LM-80, TM-21)	23
1. In-situ Temperature Measurement Test (ISTMT).....	23
2. LM-80.....	23
3. TM-21	24
4. Evaluating Lumen Maintenance.....	24
III. Testing Constraints	26

V.	Primary Use-Specific Testing Principles	26
I.	Approved or Pre-approved Housings	26
II.	Retrofit Kits	27
1.	Option A: Testing in Approved or Pre-Approved Equivalent Housings (General Purpose)	28
	Required Tests and Reports.....	29
	Fixture Level Tests.....	29
	Option A Pre-Approved Equivalentents	29
	Option A Approved Housings for Retrofit Kit Primary Uses	30
2.	Option B: Testing in a Manufacturer-Selected Housing (Luminaire Specific) ..	36
	Required Tests & Reports.....	36
	Fixture Level Tests.....	36
III.	Linear Replacement Lamps.....	37
1.	Installation Instructions	40
2.	Safety Certification Documentation.....	40
5.	Application Review.....	41
6.	Special Considerations for Linear Replacement Type-C Lamp Systems with Non-Identical Lamps	41
7.	Lamp Level Tests.....	43
8.	Testing Notes.....	43
	Fixture Level Tests: Four-Foot Linear Replacement Lamps.....	46
9.	Lumen Maintenance	51
10.	Testing Notes.....	51
IV.	Screw-Base Replacements for HID Lamps.....	52
V.	Hazardous Location Lighting	53
VI.	Four Pin-Base Replacements for CFLs.....	54
VI.	Testing and Reporting Requirements for Modular Products with External Power Supplies	64
VII.	Testing and Reporting Requirements for Dimmable and Field-Adjustable Products	65
VIII.	Testing and Reporting Requirements for Field Adjustable Light Distribution Products	68

IX.	Testing and Reporting Requirements for Color-Tunable Products	77
X.	Testing and Reporting Requirements for DC/PoE Products	82
XI.	Laboratory Requirements	87
XII.	Application Process Overview	89
I.	Prequalification Activities	89
II.	Submitting an Application	91
III.	Application Types	93
1.	Single Product Applications	93
2.	Product Family Groups	95
	Product Family Grouping Testing Guidance	99
3.	Private Label Applications	104
	Required Documentation.....	104
	Submitting a Private Label Application.....	106
XIII.	Application Fees.....	106
I.	Single Product Applications	106
II.	Family Grouping Applications.....	106
III.	Private Label Applications	107
IV.	DLC Premium Applications	108
V.	Specialty Use Designation	108
XIV.	Application Instructions.....	108
I.	General Application Instructions.....	108
1.	Manufacturer Login	108
2.	Product Application Form	108
3.	Create Online Application	109
4.	“Create New Application” Page.....	109
5.	Upload Required Documentation	109
II.	Single Product Application Instructions.....	116
1.	Tab 1: “Application Form”	117
2.	Tab 2: “Scaled Performance Table”.....	119
III.	Family Grouping Application Instructions	123
1.	Tab 1: “Application Form”	123

2.	Tab 2: "Scaled Performance Table"	126
IV.	Dimming Policy	130
V.	Manufacturer Name Updates	132
I.	Frequently Asked Questions	133
II.	DLC Qualified Products List	133
III.	Logo Guidelines	134
	Authorized Use of the DLC Logos and Trademarks.....	135
I.	DLC Program Logo	135
	Common Mistakes to Avoid	136
II.	DLC QPL Product Logo.....	136
III.	DLC QPL Premium Logo	137
	Common Mistakes to Avoid	139
IV.	The Trademarks	140
	DesignLights Consortium® and DLC®	140
	Common Mistakes to Avoid	140
	Unauthorized/Improper Use	141
	Violations of Logo Guidelines	141
	Conclusion.....	141

I. Latest Updates

- I. **May 10, 2019 Version:** Added guidance for delisting requests, manufacturer name updates, testing constraints, pre-equivalent housing requests, testing and reporting for modular products, tolerances, and driver spec sheet and ISTMT requirements. Updated the fields that are currently reported on the DLC QPL. Added clarification regarding acceptable payment methods, color tuning eligibility, multiple LEDs, testing and reporting requirements for linear replacement lamps, compatibility documentation for CFLEDs, requirements for IES files, and THD and Power Factor requirements.
- II. **March 29, 2019 Version:** Added eligibility requirements and testing and reporting guidance for Field Adjustable Light Distribution (FALD) products. Updated Private Label application requirements to clarify the process for wholly owned subsidiaries wishing to use a different model number/brand than the Parent company. Removed requirement that spec sheets submitted for application review may not include the DLC logo. Updated language referencing IES LM-80 to IES LM-80-15.
- III. **March 6, 2019 Version:** Family Grouping requirements revised to clarify that while products in the group must use identical LED packages, modules, or arrays, other design features and components are typically allowed to differ as long as the impact on performance is clear.
- IV. **January 17, 2019 Version:** ISTMT testing guidance updated to clarify the requirements for using a temporary hole to access the temperature measurement point. Clarified eligibility, testing, and reporting requirements for Type-C Linear Replacement Systems with non-identical lamps. Revised the PUD definitions for Outdoor Pole/Arm-Mounted Decorative Luminaires and Architectural Flood and Spot Luminaires.
- V. **November 7, 2018 Version: Technical Requirements V4.4 released November 1, 2018.** Technical Requirements Version 4.4 was released. Revised Primary Use definitions for Integrated Style and Linear Style Troffer Retrofit Kits. Revised Primary Use names for UL Type B and UL Type C Lamps. Added eligibility and testing requirements for field adjustable light output products and DC/PoE products.
- VI. **June 12, 2018 Version: Technical Requirements V4.3 released March 26, 2018.** Technical Requirements Version 4.3 has been released. Added Primary Use Designations and testing and reporting requirements for 3-foot and 8-foot Linear Replacement Lamps. Added 2G11 bases to eligible Four Pin-Base Replacement Lamps for CFLs. Updated the safety documentation requirements. Added testing and reporting requirements for field adjustable and color tunable products. Updated Field Adjustable policy, and revised Private Label fees. Multiple LED Policy revised to account for color tunable products.
- VII. **February 22, 2018 Version:** References to the LED Lighting Facts submission requirement removed due to the closing of the LED Lighting Facts program.
- VIII. **January 10, 2018 Version:** Requirements for evaluating Lumen Maintenance using Option 2 revised. Logo Compliance Guidelines updated.

- IX. **November 10, 2017 Version: Additional clarity provided regarding how DLC evaluates IES files.**
- X. **June 26, 2017 Version: Technical Requirements V4.2 released April 28, 2017 and Application Portal released.** Technical Requirements Version 4.2 has been released. Added Primary Use Designations for Linear Replacement Lamps, testing and reporting requirements for Hazardous Location Lighting, Allowances for products that have low CCT or high CRI. Application Portal for online submission of QPL applications released with revised online process. Added guidance for thermocouple attachment during the ISTMT.
- XI. **November 4, 2016 Version: Technical Requirement V4.1 released October 28, 2016 and Policy Updates.** Technical Requirements Version 4.1 has been released. Added Primary Use Designations for Four Pin-Base Replacements for CFLs and U-Bend replacement lamps. Policy updates include adoption of ANSI C78-277-2015, Clarification on rated data requirements, and revisions on the Private Label/Multiple Listing policy including requiring safety certification for Private Label Applications.
- XII. **September 14, 2016 Version: Revised Definition of Architectural Flood and Spot Luminaires and Logo Guidance.** Added definition to include "Billboard Lighting." Clarified logo use for general marketing materials and product specific marketing materials. Redefined logo violation policy.
- XIII. **June 10, 2016 Version: Technical Requirement V4.0 released June 1, 2016.** Minimum efficacy standards raised in each category. General application for 'Display Case Lighting' has been changed to 'Case Lighting'. Added guidance on reporting Rf and Rg values. Updated Application forms to V4.0.
- XIV. **April 15, 2016 Version: Updates to Primary Use Definitions, Retrofit Kit Policy, Family Grouping Policy, Private Label Agreement Form, Test Report Authorization Form, and Logo and Trademark Use Guidelines**
Linear replacement lamps Primary Use designation definitions updated. Retrofit Kit policy updated to include a testing option for "Luminaire Specific" retrofit kits. Family Grouping policy updated to allow for driver variations. Standard Private Label Agreement form and Test Report Authorization form introduced. The DLC Logo and Trademark Use Guidelines have been updated.
- XV. **December 14, 2015 Version: Technical Requirements V3.1**
Technical Requirements Version 3.1 has been released.
- XVI. **August 3, 2015 Version: Technical Requirements V3.0, Updates to Website FAQs, and Logo and Trademark Use Guidelines**
Technical Requirements Version 3.0 has been released. DLC website FAQs have been updated and grouped into several categories. The DLC Logo and Trademark Use Guidelines have been updated.
- XVII. **April 9, 2015 Version: Category Definitions**
Changes made to the High Bay and Low Bay Luminaires for Commercial and Industrial Buildings definitions.

XVIII. July 18, 2014 Version: Category Definitions

Changes made to the Linear Ambient Luminaires: Indirect, Indirect/Direct, Direct/Indirect, and Direct and Stairwell and Passageway Luminaires definition.

XIX. July 8, 2014 Version: Dimming Information

Consistent with the announcement of the draft policy on April 29, the DLC revised its application process to request information from manufacturers regarding the dimming capabilities of their luminaire, retrofit kit, and linear replacement lamp products for which they are seeking listing on the DLC QPL.

1. [Application Instructions](#)

Revisions made to the single product, family group, and private label application instructions to include information on how to report dimming capabilities and the new fee structure associated with reporting dimming capabilities.

2. [Dimming Policy](#)

Addition of the Dimming Policy, announced July 8, 2014.

XX. January 29, 2014 Version: LED Lighting Facts Information

Changes made to the LED Lighting Facts submission guidance to adapt to enhancements to the LED Lighting Facts submission process.

XXI. October 22, 2013 Version: Lab Testing Requirements update

Changes made to the Lab Testing Requirements table to incorporate announcement regarding final Testing Laboratory Requirements.

XXII. September 27, 2013 Version: Technical Requirements v2.1 updates

1. [Primary Use Definitions](#)

Additional primary use definitions provided for Linear Ambient Luminaires: Indirect, Linear Ambient Luminaires: Indirect/Direct, Linear Ambient Luminaires: Direct/Indirect, Linear Ambient Luminaires: Direct, and Two-Foot Linear Replacement Lamps.

2. [Retrofit Kits](#)

Additional styles of reference luminaires provided, including lantern- and teardrop-style decorative outdoor luminaires, larger shoebox and round-area luminaires, and expanded styles of fixtures for fuel pump canopies.

3. [Linear Replacement Lamps](#)

Revisions made to the Linear Replacement Lamps policy to include testing and performance requirements for Two-Foot Linear Replacement Lamp primary use.

4. [LED Lighting Facts Information](#)

Additional guidance for selecting the appropriate product type in the LED Lighting Facts submission process for Linear Ambient Luminaires: Indirect, Linear Ambient Luminaires: Indirect/Direct, Linear Ambient Luminaires:

Direct/Indirect, Linear Ambient Luminaires: Direct, and Two-Foot Linear Replacement Lamps.

XXIII. **September 10, 2013 Version: LED Lighting Facts Information**

Changes made to the LED Lighting Facts submission guidance to adapt to the new LED Lighting Facts website and submission process.

II. Purpose

This document is a technical guide for lighting equipment manufacturers seeking to place their products on the DesignLights Consortium® (DLC) Commercial LED luminaires Qualified Products List (QPL). This Manufacturer's Guide includes instructions and details on the following topics:

- Application submissions
- Approved testing laboratories and requirements
- Frequently asked questions
- Logo-use guidelines

Manufacturers should review and understand the entire document and linked files before submitting an application to the DLC. The content in this Guide is subject to change at any time. Manufacturers will be notified of any changes that occur.

Changes will supersede the content of this Guide until an updated version is produced.

Any changes will be posted in the News section and at

<https://www.designlights.org/solid-state-lighting/submit-a-product/>.

III. DesignLights Consortium Overview

I. About the DLC and the Commercial LED Luminaire Qualified Products List

The DLC is a non-profit organization whose mission is to drive efficient lighting by defining quality, facilitating thought leadership, and delivering tools and resources to the lighting market through open dialogue and collaboration. The DLC promotes quality, performance, and energy-efficient commercial-sector lighting solutions through collaboration among its regional, state, utility, and energy efficiency program members; federal agencies, luminaire manufacturers; lighting designers; and other industry stakeholders throughout the United States and Canada.

Over its history, the DLC program has driven the lighting market toward innovation by providing information, education, tools, and technical expertise for cutting-edge commercial lighting technologies and best practices. Since 2010, the DLC has administered the Commercial LED Luminaire [Qualified Products List](#) (QPL), a leading resource that identifies quality, energy-efficient LED luminaires for the commercial sector. Today, the QPL sets the bar for efficiency program incentives across the United States and Canada, while informing manufacturer product development.

The DLC is supported by its members: regional, state, utility, and national energy efficiency programs throughout the United States and Canada.

II. **Accepted Primary Uses**

The DLC currently accepts applications for 67 primary uses: 10 Outdoor Luminaires, 13 Indoor Luminaires, 6 Outdoor Retrofit Kits, 9 Indoor Retrofit Kits, 13 Linear Replacement Lamps (LED replacements for linear fluorescent lamps), 14 mogul screw-base lamps, 2 LED Replacement Lamps for CFLs, and applications for select products that may be eligible under the Specialty Use designation. Primary uses and definitions are listed below. Please refer to the [Technical Requirements](#) for the most up-to-date information about each primary use.

1. **Primary Use Eligibility**

Each product applying for inclusion on the DLC QPL must be intended for and marketed as at least one of the primary uses listed in the current Technical Requirements table or as an accepted specialty use. The DLC staff will review marketing material to determine eligibility and may ask for additional information if the intended application is not made clear by the marketing material. Additional information may include CAD drawings, installation photographs, installation videos, etc. At the request of the manufacturer, the DLC will review product specification sheets prior to an application submittal to determine eligibility for an existing primary use. Product specification sheets may be emailed to applications@designlights.org with "Product Eligibility" in the subject line. Please note that the DLC cannot review any test data prior to submittal of the application fee, and a determination that a product is eligible in an existing primary use **does not** mean the product will qualify after the complete review.

2. **The DLC and ENERGY STAR®**

The DLC program began as a request from Northeast region utility and energy efficiency programs to address LED lighting categories not covered by the ENERGY STAR® program. The DLC program focuses on commercial and industrial lighting, while ENERGY STAR remains a consumer market-focused program. If a product's intended application is not represented by the DLC Technical Requirements, manufacturers should consult the ENERGY STAR program. The DLC and ENERGY STAR programs are separate entities, each with its own set of program requirements.

3. **Primary Use Definitions**

Outdoor Pole/Arm-Mounted Area and Roadway Luminaires: Typically, street lights, parking lot lights. May be cobra-head shaped, shoebox, etc.

Outdoor Pole/Arm-Mounted Decorative Luminaires: Commonly, in-town street lights or historical reproductions, may be acorn-shaped, post-top, lantern, teardrop etc. These fixtures offer a stylish or decorative element that is clear in the luminaire design.

Outdoor Full-Cutoff Wall-Mounted Area Luminaires: Typically walkway or security lights, affixed to building wall. May be box-shaped. These products produce no uplight.

Outdoor Non-Cutoff and Semi-Cutoff Wall-Mounted Area Luminaires:

Typically walkway or security lights, affixed to building wall. May be box-shaped. The products produce a non-negligible amount of uplight.

Bollards: Architectural outdoor luminaires comprising short, upright ground-mounted units, typically giving off light from the top or the sides, and used to illuminate walkways, steps, or pathways.

Parking Garage Luminaires: Ceiling-mounted luminaires for use outdoors or in locations open to the elements in multi-deck garages.

Fuel Pump Canopy Luminaires: Ceiling-mounted luminaires for use outdoors or in structures open to the elements in gas station canopies.

Landscape/Accent Flood and Spot Luminaires: Small, low-lumen, directional luminaires intended to highlight objects and areas in outdoor lighting. Manufacturers must follow NEMA guidelines for declaring beam spread.

Architectural Flood and Spot Luminaires: Directional luminaires intended to highlight architecture, objects or areas in outdoor lighting, that do not include roadway or tunnel lighting. May include billboard lighting. Manufacturers must follow NEMA guidelines for declaring beam spread.

Stairwell and Passageway Luminaires: Corner- or surface-mounted luminaires that provide lighting in stairwells and passageways. Luminaires must meet one of the following conditions: include integral controls, operate off of remote sensors where remote sensor is packaged together with the luminaire under a single model number, or be designed to operate off of remote sensors, where the luminaire and sensors are sold separately, but the luminaire has features enabling communication with a remote sensor. Controls must assure the luminaire reverts to lower-power, lower-light output state when there are no occupants in the vicinity.

Wall-Wash Luminaires: Luminaires designed to illuminate walls in interior spaces.

Track or Mono-point Luminaires: Usually ceiling-mounted tracks or fixed single head. Adjustable aim "cans". Complete LED luminaires (not replacement lamps in existing cans such as PAR 38 or MR16 lamps).**If your product does not meet this definition you may qualify under ENERGY STAR's Recessed Downlight or Surface Mounted with Directional Head primary use.***

Vertical Refrigerated Case Luminaires-center: Strip lights in refrigerator cases, vertically mounted along refrigerator case door mullions. Primary use covers only complete luminaires, with all necessary components. Replacement lamps are not currently eligible under this primary use.

Vertical Refrigerated Case Luminaires-end: Strip lights in refrigerator cases, vertically mounted along refrigerator case door mullions. Primary use covers only complete luminaires, with all necessary components. Replacement lamps are not currently eligible under this primary use.

Horizontal Refrigerated Case Luminaires: Strip lights in refrigerator cases, horizontally mounted along refrigerator case shelves or canopies. Primary use covers only complete luminaires, with all necessary components. Replacement lamps are not currently eligible under this primary use.

Display Case Luminaires: Strip lights, usually mounted horizontally at frame edges of glass case. Replacement lamps such as MR16 or PAR 38 lamps are not eligible.

2x2, 1x4, 2x4 Luminaires for Ambient Lighting of Interior Commercial Spaces: Common recessed, suspended, or surface-mounted luminaires intended to provide ambient lighting in settings such as offices spaces, schools, retail stores, and other commercial environments. Products submitted in these categories must meet the stated form factors with a tolerance of ± 4 inches.

Direct Linear Ambient Luminaires: Suspended- or surface-mounted luminaires or recessed luminaires, no wider than 12", designed to provide direct lighting in indoor spaces. Products may be designed to be installed end-to-end to create long chains, and may be described as direct, indirect, semi-direct, semi-indirect, or general ambient, depending on intended lighting distribution. Utilitarian "strip" style fixtures are also eligible under this primary use. Products intended for cove lighting are not currently eligible under this primary use.

Linear Ambient Luminaires with Indirect Component: Suspended-mounted luminaires or recessed luminaires, no wider than 12", designed to provide ambient lighting in indoor spaces, including an intentional lighting component that is indirect. Products may be designed to be installed end-to-end to create long chains, and may be described as indirect, semi-direct, semi-indirect, direct-indirect, indirect-direct, or general ambient, depending on intended lighting distribution. Utilitarian "strip" style fixtures are not eligible under this primary use. Products intended for cove lighting are not currently eligible under this primary use.

High-Bay Luminaires for Commercial and Industrial Buildings: Pendant, recessed, or surface-mounted luminaires, specific for indoor high ceiling spaces (intended for ceilings ≥ 25 feet).

Low-Bay Luminaires for Commercial and Industrial Buildings: Pendant, recessed, or surface-mounted luminaires, specific for indoor ceiling spaces (intended for ceilings < 25 feet).

High-Bay Aisle Luminaires: Pendant or surface-mounted luminaires specific for indoor high ceiling spaces (intended for ceilings ≥ 25 feet), in settings that require the lighting of aisles.

Retrofit Kits for Outdoor Pole/Arm-Mounted Area and Roadway Luminaires: Integrated-style kits that replace all reflectors and optical systems of existing luminaires. Not screw-in "lamps" intended as HID replacements.

Retrofit Kits for Outdoor Pole/Arm-Mounted Decorative Luminaires: Integrated-style kits that replace all reflectors and optical systems of existing luminaire. Not screw-in "lamps" intended as HID replacements.

Retrofit Kits for Large Outdoor Pole/Arm-Mounted Area and Roadway Luminaires: Integrated-style kits that replace all reflectors and optical systems of existing luminaires. Not screw-in "lamps" intended as HID replacements.

Retrofit Kits for Outdoor Full-Cutoff Wall-Mounted Luminaires: Integrated-style kits that replace all reflectors and optical systems of existing luminaires. Not screw-in "lamps" intended as HID replacements.

Retrofit Kits for Parking Garage Luminaires: Integrated-style kits that replace all reflectors and optical systems of existing luminaires. Not screw-in "lamps" intended as HID replacements.

Retrofit Kits for Fuel Pump Canopy Luminaires: Integrated-style kits that replace all reflectors and optical systems of existing luminaires. Not screw-in "lamps" intended as HID replacements.

Integrated-Style Retrofit Kits for 2x2, 1x4, 2x4 Luminaires for Ambient Lighting of Interior Commercial Spaces: Retrofit systems which replace the entire optical systems of the existing luminaire and fully integrate a replacement light source, optics, and reflective panel, where the panel connects with the fixture housing front along two opposing sides or more and when installed, fully conceals the interior of the existing housing. These retrofit kits may not employ existing lamp holders or "pin" bases, and retrofit kits that have exposed LEDs, tube style lenses, or bar-style components are not eligible.

Linear-Style Retrofit Kits for 2x2, 1x4, 2x4 Luminaires for Ambient Lighting of Interior Commercial Spaces: Tube-shaped or strip-style retrofit kits for troffers. Products in this category typically do not replace the optical systems/lenses of the existing luminaire, and leave the basic form of the existing luminaire intact or exposed. These retrofit kits may not employ existing lamp holders or "pin" bases

Retrofit Kits for Direct Linear Ambient Luminaires: Retrofit kits for “strip” luminaires and other types of linear ambient luminaires. Do not employ existing lamp holders or “pin” bases.

Retrofit Kits for High-Bay Luminaires for Commercial and Industrial Buildings: Integrated-style kits that replace all reflectors and optical systems of existing luminaires. Not screw-in “lamps” intended as HID replacements.

Retrofit Kits for Low-Bay Luminaires for Commercial and Industrial Buildings: Integrated-style kits that replace all reflectors and optical systems of existing luminaires. Not screw-in “lamps” intended as HID replacements.

Linear Replacement Lamps (“plug and play”) (UL Type A): Two-foot, three-foot, four-foot, eight-foot, and U-bend LED “tubes” designed to replace two-foot, three-foot, four-foot, eight-foot, and U-bend fluorescent lamps, respectively. Products in this primary use employ lamp holders to connect to the fixture being retrofitted and are designed to be “plug and play” replacements for fluorescent lamps. That is, products in this category can operate off an existing fluorescent ballast, and do not require mechanical or electrical changes to the fixture. Note that due to testing considerations, at this time only products that can operate off electronic instant start ballasts are eligible. Replacement lamps designed to operate off existing magnetic ballasts, or off other types of electronic ballasts, are not eligible. Please note reference to UL type is derived from UL 1993, 4th edition, 2012-12-04 Section SA6.13.1. (See Replacement Lamps page for more detail on testing requirements)

Internal-driver/Line Voltage (UL Type B) Lamps: Two-foot, three-foot, four-foot, eight-foot, and U-bend LED “tubes” designed to replace two-foot, three-foot, four-foot, eight-foot, and U-bend fluorescent lamps, respectively. Products in this primary use employ lamp holders to connect to the fixture being retrofitted, but do not operate off the existing fluorescent ballast. These products require rewiring of the existing fixture to bypass the ballast and send line voltage directly to the lamp holders. Please note reference to UL type is derived from UL 1993, 4th edition, 2012-12-04 Section SA6.13.1. (See Replacement Lamps page for more detail on testing requirements)

NOTE: Internally-driven lamps that can operate either off a fluorescent ballast or off line-voltage will be denoted as “Dual Mode” on the QPL. Products must be tested under worst-case operating condition.

External Driver (UL Type C) Lamps: Two-foot, three-foot, four-foot, eight-foot, and U-bend LED “tubes” designed to replace two-foot, three-foot, four-foot, eight-foot, and U-bend fluorescent lamps, respectively. Products in this category employ lamp holders to connect to the fixture being retrofitted, do not operate off the existing fluorescent ballast, and require rewiring of the existing fixture to replace the ballast with an external driver. The lamp

holders are then wired to receive only the low-voltage electricity that is supplied by that external driver. Note that due to testing considerations, only one- or two-lamp four-foot lamp systems, or one- and three-lamp two-foot lamp systems are eligible. Development of provisions for systems with alternative numbers of lamps operating off single drivers is under consideration. Please note reference to UL type is derived from UL 1993, 4th edition, 2012-12-04 Section SA6.13.1. (See Linear Replacement Lamps page for more detail on testing requirements)

NOTE: Multi-lamp Type-C lamp systems are in general expected to have multiple lamps of the exact same type. For multi-lamp Type-C systems where the lamps within the system are not identical, [additional restrictions and testing rules apply](#).

Dual Mode Internal Driver Linear Replacement Lamps (UL Type A): Two-foot, three-foot, four-foot, eight-foot, and U-bend LED "tubes" designed to replace two-foot, three-foot, four-foot, eight-foot, and U-bend fluorescent lamps, respectively. Products in this category have the ability to operate off the existing fluorescent ballast and also have the ability to operate off of line voltage if the troffer is rewired to bypass the ballast. These products connect to the troffer using standard pin-base connections to the lamp holders. Note that at this time only products that can operate off electronic instant start ballasts are eligible. Products that are designed to operate off magnetic or non-instant start electronic ballasts are not eligible. Please note reference to UL type is derived from UL 1993, 4th edition, 2012-12-04 Section SA6.13.1. (See Linear Replacement Lamps page for more detail on testing requirements)

Mogul Screw-Base Replacements for HID Lamps for Outdoor Pole/Arm-Mounted Area and Roadway Luminaires (Internal Driver/Type B): LED replacement lamps for HID lamps which require the existing HID ballast to be bypassed and the lamp holder to be wired with line voltage, used in outdoor pole/arm-mounted area and roadway luminaires. Only mogul-base (E39) products are eligible at this time. Lamps are only considered qualified in the end-uses they are listed in.

Mogul Screw-Base Replacements for HID Lamps for Outdoor Full-Cutoff Wall-Mounted Area Luminaires (Internal Driver/Type B): LED replacement lamps for HID lamps which require the existing HID ballast to be bypassed and the lamp holder to be wired with line voltage, used in outdoor wall-mounted area luminaires. Only mogul-base (E39) products are eligible at this time. Lamps are only considered qualified in the end-uses they are listed in.

Mogul Screw-Base Replacements for HID Lamps for Outdoor Decorative Luminaires (Internal Driver/Type B): LED replacement lamps

for HID lamps which require the existing HID ballast to be bypassed and the lamp holder to be wired with line voltage, used in outdoor decorative luminaires. Only mogul-base (E39) products are eligible at this time. Lamps are only considered qualified in the end-uses they are listed in.

Mogul Screw-Base Replacements for HID Lamps for Parking Garage Luminaires (Internal Driver/Type B): LED replacement lamps for HID lamps which require the existing HID ballast to be bypassed and the lamp holder to be wired with line voltage, used in parking garage luminaires. Only mogul-base (E39) products are eligible at this time. Lamps are only considered qualified in the end-uses they are listed in.

Mogul Screw-Base Replacements for HID Lamps for Fuel Pump Canopy Luminaires (Internal Driver/Type B): LED replacement lamps for HID lamps which require the existing HID ballast to be bypassed and the lamp holder to be wired with line voltage, used in fuel pump canopy luminaires. Only mogul-base (E39) products are eligible at this time. Lamps are only considered qualified in the end-uses they are listed in.

Mogul Screw-Base Replacements for HID Lamps for High-bay Luminaires (Internal Driver/Type B): LED replacement lamps for HID lamps which require the existing HID ballast to be bypassed and the lamp holder to be wired with line voltage, used in high-bay luminaires. Only mogul-base (E39) products are eligible at this time. Lamps are only considered qualified in the end-uses they are listed in.

Mogul Screw-Base Replacements for HID Lamps for Low-bay Luminaires (Internal Driver/Type B): LED replacement lamps for HID lamps which require the existing HID ballast to be bypassed and the lamp holder to be wired with line voltage, used in low-bay luminaires. Only mogul-base (E39) products are eligible at this time. Lamps are only considered qualified in the end-uses they are listed in.

Mogul Screw-Base Replacements for HID Lamps for Outdoor Pole/Arm-Mounted Area and Roadway Luminaires (External Driver/Type C): LED replacement lamps for HID lamps which require the existing HID ballast to be replaced with an external LED driver (the lamp holder is not wired with line voltage), used in outdoor pole/arm-mounted area and roadway luminaires. Only mogul-base (E39) products are eligible at this time. Lamps are only considered qualified in the end-uses they are listed in.

Mogul Screw-Base Replacements for HID Lamps for Outdoor Pole/Arm-Mounted Area and Roadway Luminaires (External Driver/Type C): LED replacement lamps for HID lamps which require the existing HID ballast to be replaced with an external LED driver (the lamp holder is not wired with line voltage), used in outdoor pole/arm-mounted area

and roadway luminaires. Only mogul-base (E39) products are eligible at this time. Lamps are only considered qualified in the end-uses they are listed in.

Mogul Screw-Base Replacements for HID Lamps for Outdoor Full-Cutoff Wall-Mounted Area Luminaires (External Driver/Type C): LED replacement lamps for HID lamps which require the existing HID ballast to be replaced with an external LED driver (the lamp holder is not wired with line voltage), used in outdoor full-cutoff wall-mounted area luminaires. Only mogul-base (E39) products are eligible at this time. Lamps are only considered qualified in the end-uses they are listed in.

Mogul Screw-Base Replacements for HID Lamps for Outdoor Decorative Luminaires (External Driver/Type C): LED replacement lamps for HID lamps which require the existing HID ballast to be replaced with an external LED driver (the lamp holder is not wired with line voltage), used in outdoor decorative luminaires. Only mogul-base (E39) products are eligible at this time. Lamps are only considered qualified in the end-uses they are listed in.

Mogul Screw-Base Replacements for HID Lamps for Parking Garage Luminaires (External Driver/Type C): LED replacement lamps for HID lamps which require the existing HID ballast to be replaced with an external LED driver (the lamp holder is not wired with line voltage), used in parking garage luminaires. Only mogul-base (E39) products are eligible at this time. Lamps are only considered qualified in the end-uses they are listed in.

Mogul Screw-Base Replacements for HID Lamps for Fuel Pump Canopy Luminaires (External Driver/Type C): LED replacement lamps for HID lamps which require the existing HID ballast to be replaced with an external LED driver (the lamp holder is not wired with line voltage), used in fuel pump canopy luminaires. Only mogul-base (E39) products are eligible at this time. Lamps are only considered qualified in the end-uses they are listed in.

Mogul Screw-Base Replacements for HID Lamps for High-bay Luminaires (External Driver/Type C): LED replacement lamps for HID lamps which require the existing HID ballast to be replaced with an external LED driver (the lamp holder is not wired with line voltage), used in high-bay luminaires. Only mogul-base (E39) products are eligible at this time. Lamps are only considered qualified in the end-uses they are listed in.

Mogul Screw-Base Replacements for HID Lamps for Low-bay Luminaires (External Driver/Type C): LED replacement lamps for HID lamps which require the existing HID ballast to be replaced with an external LED driver (the lamp holder is not wired with line voltage), used in low-bay luminaires. Only mogul-base (E39) products are eligible at this time. Lamps are only considered qualified in the end-uses they are listed in.

Four Pin-Base Replacement Lamps for CFLs ("plug and play") (UL Type A): G24q- and GX24q-base LED lamps, and 2G11 base lamps greater than or equal to twenty inches, designed to replace compact fluorescent lamps (CFLs). At this time, G24q/GX24q and 2G11 UL Type A lamps (designed to operate utilizing the existing CFL ballast), and 2G11 UL Type B (designed to operate utilizing direct line voltage), 2G11 UL Type C (designed to operate utilizing a non-integral driver), and 2G11 UL dual mode (designed to operate utilizing the existing CFL ballast or direct line voltage) are all eligible. G24q or GX24q UL Type B lamps and UL Type C lamps, as well as products with other bases (including 2-pin products), are not eligible. At this time, only products that can operate utilizing specific ballast types are eligible.

III. **DLC Classifications**

1. DLC Standard Classification

Products submitted under the DLC Standard classification are reviewed under the DLC Standard requirements listed on the [Technical Requirements Table](#).

Standard classification applications include the data and materials requirements listed on the [Single Product](#) and [Family Grouping](#) web pages.

2. DLC Premium Classification

DLC Premium is a higher-performance classification for luminaires and retrofit kits. Products submitted to the DLC Premium classification must meet higher efficacy and lumen maintenance requirements outlined in the [Technical Requirements Table](#) and must also provide a driver ISTMT and information about integral controls, in addition to meeting all of the base requirements. If a manufacturer seeks qualification of its products to the DLC Premium classification, it must provide all the necessary testing to demonstrate the products meet the higher classification's additional requirements.

Additional detail on DLC Premium requirements can be found on the [DLC Premium web page](#) and the [Technical Requirements Table](#).

IV. **Allowances**

While the primary intent of the DLC SSL QPL is to serve the energy-savings goals for the DLC member programs, it is not the intent of the DLC or its membership to drive market development or customer choice away from features that contribute to the overall quality of the light fixture or the quality of the lighting for a particular space. DLC and its membership are therefore sensitive to concerns that high efficacy thresholds may drive features in a way that are not intended. DLC will grant allowances to efficacy requirements, applicable to both tested and reported performance values.

Adopted Allowances – CCT, CRI

Products with low CCT or high CRI can qualify for listing on the QPL at slightly reduced efficacy levels, as noted in the table below.

Feature or Performance Metric	Allowances to Efficacy
CCT: $\leq 3000\text{K}$, $> 2700\text{K}$	-3%
CCT: $\leq 2700\text{K}$	-5%
CRI*: $R_a \geq 90$ (* must also conduct TM-30 testing and report results per TM-30 policies)	-5%

Please note

that allowances are not cumulative. That is, products may not take multiple allowances, even if they exhibit more than one feature for which an allowance is available. For example, a 2700K, 90CRI product may utilize a maximum allowance of 5%, to be applied to the efficacy requirement for the Category and General Application to which it is applying. However, a product may take advantage of an efficacy allowance in conjunction with the luminaire efficacy tolerance, as stated in Table 5. In this situation, the allowance would be applied first, and then the tolerance.

V. Tolerances

The table below presents tolerances that apply to all metrics listed in the above in Technical Requirements Table V4.3. These tolerances are referenced in the [ENERGY STAR® Manufacturer's Guide](#). For zonal lumen tolerances specific to each Primary Use designation, please refer to Table 4 of the [Technical Requirements](#).

Performance Metric	Tolerance
Light Output	$\pm 10\%$
Luminaire Efficacy	-3%
Allowable CCT	Defined by ANSI C78.377-2015†
CRI	-2 points
Power Factor	-3%
Total Harmonic Distortion	+5%
Drive Current (LM-80)	+5%

† ANSI C78.377-2015 also referred to for Duv and (x,y) chromaticity coordinates tolerances for indoor categories.

For any performance metrics that are measured as a percentage, corresponding tolerances refer to percentage points. For example, a power factor requirement of ≥ 0.90 (i.e. $\geq 90\%$) with a -3% tolerance implies a functional requirement of ≥ 0.87 (i.e. $\geq 87\%$). For performance metrics that are not measured as a percentage, the tolerance is a percentage of the required value. For example, for a minimum efficacy requirement of 60 lm/W with a -3% tolerance, the functional requirement is 58.2 lm/W (i.e. $60 - 3\% = 58.2$).

Measured temperature from the ISTMT

According to ENERGY STAR Manufacturer's Guide for Qualifying Solid State Lighting Luminaires – Version 2.1, the measured temperature from an ISTMT has a tolerance of $\leq 1.1^{\circ}\text{C}$ or 0.4%, whichever is greater due to thermocouple tolerance. This may change the appropriate In-Situ case temperature ($T_c,^{\circ}\text{C}$) to enter into the ENERGY STAR TM-21 calculator. For example, a measured In-Situ case temperature of 86.1°C may be entered as 85°C to comply with an 85°C case temperature data set from the LM-80 report.

Understanding Testing Principles

For all primary uses, the DLC requires three main test reports to accompany an application: IES LM-79-08 (LM-79), In-situ Temperature Measurement Test (ISTMT), and IES LM-80-15. Each test report must include a unique, relevant part number, as well as a test date and test location. Please note that the DLC follows the [ENERGY STAR Guidance](#) for lumen maintenance testing, including:

- LM-80 and ISTMT test procedures
- Content and application of LM-80 reports
- Successor devices

Please note, the DLC is interested in the performance of the production-ready product seeking qualification. As such, test data on prototypes will not be accepted for DLC submissions. Testing must be on production-ready models that are identical in design and construction to those that are being or will be sold.

VI. Photometric and Electric Testing (LM-79)

The *LM-79 Approved Method: Electrical and Photometric Measurements of Solid-State Lighting Products* includes three sections: Section 9: Total Flux Measurements; Section 10: Luminous Intensity Measurements; and Section 12: Color Characteristics Measurements. Manufacturers must also submit the IES file containing Section 10 measurements to verify compliance with the zonal lumen density or spacing criteria requirements.

VII. **Lumen Maintenance (ISTMT, LM-80, TM-21)**

1. In-situ Temperature Measurement Test (ISTMT)

The ISTMT is a test method derived from safety testing standards, such as ANSI/UL 1598, which measures the hottest LED package/module/array in the luminaire/retrofit/lamp system. The ISTMT must be conducted with the luminaire installed in its appropriate application, as defined in the appropriate safety standard.

a) Temperature Measurement Point

LED package/model/array manufacturers designate specific locations on the product as alternate points for measuring the junction temperature of the LED package/module/array. The alternate points for measuring the junction temperature are collectively referred to as the TMP_{LED} , and vary from manufacturer to manufacturer. For example, some manufacturers use the solder point (t_s), package case temperature (t_c), or board temperature (t_b). However, all TMP_{LED} locations serve the same purpose: to correlate an external temperature to the junction temperature, which is used to determine the LED lumen maintenance. To use the TMP_{LED} to determine LED lumen maintenance, the TMP_{LED} used during the ISTMT must match the TMP_{LED} used during the LM-80.

To verify that the TMP_{LED} was placed correctly and matches the TMP_{LED} used during the LM-80, all applications must include a photograph that clearly illustrates the thermocouple placement during the ISTMT, as well as a schematic diagram illustrating the LED package/module/array manufacturer's specified TMP_{LED} .

For [Option 1: Component Performance](#), the LED package/module/array TMP must be accessible to allow temporary attachment of a thermocouple for measuring the in situ operating temperature. Access to the TMP may be achieved via a temporary hole in the housing (suggested to be no larger than 0.375" in diameter), which is then tightly resealed during testing with putty or other flexible sealant. DLC may seek additional details regarding the temporary hole to confirm appropriate action was taken to reseal it. The size and access port shall be clearly documented. If the TMP cannot be accessed, the product must go through [Option 2 Luminaire Performance](#).

2. LM-80

The *LM-80-15 Approved Method: Measuring Lumen Maintenance of LED Light Sources* requires that LED packages/modules/arrays be operated for at least 6,000 hours, at a minimum of 3 case temperatures: 55 °C, 85 °C, and a third temperature determined by the manufacturer. Light output, forward voltage, and other performance metrics are measured and recorded at roughly every 1,000 hours for a minimum of 6,000 hours.

3. TM-21

The *TM-21 Projecting Long Term Lumen Maintenance of LED Light Sources* is a standard that relates ISTMT results to LM-80 data to determine the long-term lumen maintenance of an LED light source. TM-21 applies an exponential least squares curve-fit through the average values provided in the LM-80. Luminous flux measurements may be projected to 5.5 or 6 times the LM-80 test length, depending on the number of samples reported in the LM-80. For 20 or more samples, projections may be 6 times the LM-80 test duration; for 10-19 samples, projections may be 5.5 times the LM-80 test duration. TM-21 does not apply to tests with fewer than 10 samples.

4. Evaluating Lumen Maintenance

The DLC determines compliance with the 50,000-hour lumen maintenance requirement through either Option 1: Component Performance or Option 2: Luminaire Performance.

a) Option 1: Component Performance

Component Performance allows the manufacturer to demonstrate compliance with the lumen maintenance requirements by providing an ISTMT (described above), LM-80 report for the package/module/array used in the luminaire/retrofit/lamp system, and completed copy of the ENERGY STAR TM-21 calculator.

To evaluate Component Performance compliance, the following conditions must be met:

- (1) The highest measured temperature in the ISTMT must fall below the highest measured case temperature in the LM-80.
- (2) The TMP_{LED} location in the ISTMT must match the TMP_{LED} location in the LM-80 and the LED manufacturer's specified location.
- (3) The LED drive current in the luminaire/retrofit/lamp system must be less than or equal to the LED drive current measured in the LM-80.
- (4) The lumen maintenance at time (t) calculated in the ENERGY STAR TM-21 calculator must be greater than or equal to the corresponding lumen maintenance percentage at the projected end point listed in the table below.

Projected End Point	Required Lumen Maintenance for 50,000 Hours
33,000	≥ 79.03%
36,000	≥ 77.35%
38,500	≥ 75.98%
42,000	≥ 74.11%
44,000	≥ 73.06%

48,000	≥ 71.01%
49,500	≥ 70.25%
50,000	≥ 70.00%

b) Option 2: Luminaire Performance

In instances where Option 1: Component Performance is not applicable, as with products using secondary optics with remote phosphors or when LM-80 data is unavailable, manufacturers may demonstrate compliance with the lumen maintenance requirements through Luminaire Performance. Luminaire Performance requires luminaire-level testing according to the IES LM-84-14 *Approved Method: Measuring Luminous Flux and Color Maintenance of LED Lamps, Light Engines, and Luminaires* test standard and applying the IES TM-28-14 *Projecting Long-Term Luminous Flux Maintenance of LED Lamps and Luminaires* projection methodology. For Option 2, DLC uses a pass/fail threshold for lumen maintenance compliance. The projection from TM-28 must project to at least 6,000 hours and the lumen maintenance projection at the projection end point must be consistent with an L₇₀ of 50,000 hours. The DLC uses the ENERGY STAR TM-28 calculator to determine compliance with the lumen maintenance requirements if choosing Option 2. To ensure documentation and testing is completed correctly, please contact DLC at applications@designlights.org prior to submitting an application using Option 2.

c) Multiple LEDs

Products employing multiple types of LEDs are eligible so long as the types and quantities of the LED packages/modules/arrays are known. That is, products where variable numbers of LEDs are dynamically chosen, and therefore the precise construction of any given product is not defined, are not eligible. Policy development for appropriate evaluation of this type of product is under consideration.

For products using multiple LED types, including color-tunable products, an LM-80, ISTMT, and TM-21 projection will be needed for each type of LED present in the product. As per normal thermal testing rules, ISTMTs must be conducted on the hottest LED of each type.

To qualify, the product must demonstrate compliance with the lumen maintenance requirements for each LED present. LM-80 reports and associated TM-21 projections should be included for each type of LED.

Each LED must demonstrate the necessary L70 of the category the product is seeking qualification under, per the DLC lumen maintenance rules Each LED must demonstrate the required L70 of $\geq 50,000$ hours.

VIII. **Testing Constraints**

DLC understands that in some scenarios, products that are required to be tested may not physically fit within the testing apparatus needed to conduct testing. This is often seen with 8-foot linear-type luminaires that do not fit in standard goniophotometers, though other restrictions may exist. In the event that a product is identified as requiring testing for a DLC application, but cannot be tested due to the constraints of the testing equipment, DLC will need to understand and collect the following information:

- a) Specific reasons why the product in question cannot be tested.
- b) A proposal from the manufacturer on how to evaluate the performance of the product. Proposals must be technically sound and demonstrate a thorough understanding of the product's construction and performance affecting variables.
- c) Rationale for why the proposal is representative of the product's performance.

Proposals, once complete with the details mentioned above, will be reviewed on a case-by-case basis by DLC program management. Please provide this information ahead of submitting an application as proposals need to be approved prior to allowing the use of alternate data within an application. This will help ensure application reviews are completed as efficiently as possible. As always, DLC reserves the right to require additional information, and manufacturers should be prepared to provide documentation that addresses concerns that arise.

Development of standard procedures for evaluating performance of products that are too large for testing equipment is on the DLC policy development wishlist. DLC welcomes proposals for standardizing this process and should be sent to info@designlights.org.

IV. **Primary Use-Specific Testing Principles**

In addition to the general testing principles outlined under [Understanding Testing Principles](#) above, the DLC also sets primary use-specific testing requirements.

I. **Approved or Pre-approved Housings**

For Primary Uses that require testing in a reference housing fixture, please refer to the sections linked below or follow the instructions for submitting a pre-approved equivalent request.

- [Retrofit Kits](#)

- [Screw-Base Replacements for HID Lamps](#)
- [Two-Foot Linear Replacement Lamps](#)
- [Three-Foot Linear Replacement Lamps](#)
- [Four-Foot Linear Replacement Lamps](#)
- [Eight-Foot Linear Replacement Lamps](#)
- [U-Bend Replacement Lamps](#)
- [Four Pin-Base Replacement Lamps for CFLs \(Luminaires\)](#)
- [Four Pin-Base Replacement Lamps for CFLs \(Ballasts\)](#)
- [G24q/GX24q Base Lamps](#)
 - [ISTMT](#)
 - [Compatibility](#)
- [2G11 Base Lamps](#)
 - [ISTMT](#)

While the DLC does not require testing in all approved and pre-approved housings available for each retrofit kit or replacement lamp Primary Use, the approved and pre-approved housings selected for testing are intended to provide similar, common environments for which the retrofit kit may be installed in the field. As such, it is the DLC's expectation that the submitted retrofit kit should meet the requirements regardless of the housing chosen for testing. If testing is provided showing that the product does not meet the requirements in a specific housing, the products will not be able to be qualified and listed on the QPL.

Pre-approved Equivalent requests

Pre-approved Equivalent requests may be sent to applications@designlights.org.

In reviewing Pre-approved Equivalent requests, the DLC is verifying that the requested incumbent fixture is/has:

- Commonly used in the application category for which the retrofit kit is applying
- Specifications that align with the application category for which the retrofit kit is applying
- Similar thermal environment (i.e. internal volume and construction materials) to those listed under the Approved section of each Primary Use

If the above information is not clear in the spec sheet provided for the requested fixture, the DLC will require additional information to ensure the requested fixture aligns with the Approved fixtures of that given Primary Use.

II. Retrofit Kits

The DLC will accept QPL applications for SSL retrofit kits. Manufacturers have two options for testing retrofit kits, defined below as [Option A](#), testing in Approved or Pre-Approved Equivalent Housings or [Option B](#), testing in a manufacturer-selected housing.

In order for DLC reviewers to verify that the retrofit kit was tested in an Approved Housing, the housing used for testing must be clearly documented in the LM-79 and ISTMT reports submitted with the application. If the housing used for testing is not clearly documented in the test reports, and the test reports cannot be updated with this information, DLC will require confirmation of the housing used for testing from the laboratory(ies) that conducted the testing. Please review the [FAQs page](#) for additional policy clarifications.

All Retrofit Kit applications, regardless of the option chosen for testing, must also include the following:

Installation Instructions

Installation instruction sheets must be submitted with the application to indicate how the retrofit kit will be installed in an existing fixture in the field. These installation instructions must be the same ones provided to customers and installers in the market.

Safety Certification Documentation

Documentation of safety certification for the retrofit kit must be submitted with the application. This documentation must indicate safety certification has been obtained from an applicable safety certification organization. DLC staff will not interpret safety *testing* as proof that safety certification has been obtained.

1. Option A: Testing in Approved or Pre-Approved Equivalent Housings (General Purpose)

Option A is intended for retrofit kits that are designed to retrofit typical incumbent luminaires. The testing and reporting requirements described below are intended to subject retrofit kits to conditions in typical fixtures in order to assure confidence in performance.

For this option, the DLC specifies typical fixture housings in which retrofit products are to be tested, referred to as [Approved Housings](#). This is done to provide testing results under common conditions in which the retrofit kits would be installed. In providing this list of typical fixture housings, the DLC does not endorse or exclude any particular make or model frame for use in energy efficiency programs. Note that each recommended variation includes the statement, "or Pre-approved Equivalents" is also listed as an option. In selecting a fixture for testing, the applicant shall consider the purpose of subjecting the tested kit to extreme confinement for thermal endurance.

Retrofit kits tested in an approved, or pre-approved equivalent, housing are considered qualified when installed in any housing of the same end-use. For example, a shoe-box style retrofit kit tested in the Lithonia KAD Contour Series approved housing, would be considered qualified (should it meet all technical requirements) when installed in any application applicable to the "Retrofit Kits for Outdoor Pole/Arm-Mounted Area and Roadway Luminaires" Primary Use designation. If a retrofit kit can be used in multiple Primary Uses, manufacturers will need to provide testing in a housing applicable to each

Primary Use in order to be considered qualified in those end-uses. Products tested according to Option A will be designated as "General Purpose" on the QPL.

Manufacturers shall test and report fixture performance under the following restrictions and conditions:

Required Tests and Reports

All DLC QPL testing and reporting requirements that apply to new fixtures shall also apply to any retrofit kit application: e.g., LM-79, ISTMT, IES file, TM-21 projection. (Note that for lumen maintenance testing, the source manufacturer is responsible for the LM-80 test of the LED package, array, or module. A report resulting from this test must be passed on to the DLC by the applicant, as specified in the application instructions.) LM-79 reports for retrofit kits should be submitted directly by the applicant to DLC.

Fixture Level Tests

LM-79 and ISTMT (or Option 2 lumen maintenance determination, if selected), shall be conducted in a fully functional reference fixture with the kit properly installed per manufacturer's instructions.

Retrofit kits need to be tested in (i.e. supply an LM-79, ISTMT, IES file from testing in) only *one* of the fixtures approved, or pre-approved, below. The option you choose to use for [lumen maintenance](#) compliance will determine how many tests you need. If you choose Option 1: one LM-80 report and TM-21 projection is needed per LED package, array, or module as necessary according to the [multiple LEDs policy](#). If you choose Option 2: you will need to conduct luminaire-level testing of the retrofit kit installed in an approved fixture housing following the LM-84-14 test standard.

Option A Pre-Approved Equivalent

As noted, DLC does not endorse or exclude any particular make or model of reference fixture. Options are listed to illustrate common fixtures of that type. With approval from the DLC, manufacturers may test in alternative fixtures. Pre-approved fixtures must meet the following conditions:

Alternative fixtures must be commonly used in the application category intended to be applied for. Documentation may be required to demonstrate fixtures appropriate use if questions arise.

Alternative fixtures must provide similar thermal environments to those listed and may not be significantly different in internal volume or construction materials. Particularly, alternative fixtures may not be significantly different in internal volume or construction materials.

A list of pre-approved equivalent fixtures for each Primary Use will be maintained throughout each "Pre-Approved Equivalent" section of each

retrofit kit category. Please refer to <https://www.designlights.org/solid-state-lighting/testing-reporting-requirements/retrofit-kits/> for the most up to date list of pre-approved equivalent housings.

To request that a fixture be considered as a pre-approved equivalent for testing purposes, please send the spec sheet for the fixture to applications@designlights.org, along with a spec sheet for your retrofit kit. DLC review staff may need additional details, depending on the request and details available in the spec sheet.

Option A Approved Housings for Retrofit Kit Primary Uses

Manufacturer shall select a fixture for testing based on the intended application of the retrofit kit:

Outdoor Pole/Arm-Mounted Area and Roadway Luminaires

- If the kit is specific to shoebox fixtures (not applicable to cobra-heads), choose a fixture from among those listed herein under shoebox.
- If the kit is specific to cobra-head fixtures (not applicable to shoeboxes), choose a fixture from among those listed herein under cobra-head.
- If the kit may be applied to both cobra-heads and shoebox fixtures, choose a fixture from among those listed herein under either shoebox or cobra-head.
- Kits designed for larger housings must demonstrate that they do not fit in the smaller housing sizes by submitting a CAD file with the kit installed in the reference small cobra-head.

CAD Files:

[Combo_Small.SLDASM](#)

[Combo_Small.pdf](#)

- **Cobra-Head Fixtures Retrofit Kits:**
 - American Electric Roadway Series 115 Fixture
 - GE M250R2 fixture
 - Kim Archetype SAR
 - Pre-approved equivalent*

- **Shoebox Fixtures Retrofit Kits:**
 - WideLite XL Excel-Lyte 400
 - Lithonia KAD Contour Series
 - Lumark TR Tribute
 - Kim Archetype SAR
 - Pre-approved equivalent*

- **Retrofit Kits for Larger Size Housings:**
 - American Electric Roadway Series 125 Fixture
 - GE M400R2 fixture

- Ruud PR2-22
- Kim VLA29
- Pre-approved equivalent*

*The fixtures listed under “pre-approved equivalent” have been requested by applicants and approved for use in retrofit kit testing. Refer to [Retrofit Kit](#) policy to up to date pre-approved equivalents

Note that at this time, DLC does not qualify screw-in “lamps” intended as HID replacements as retrofit kits.

Outdoor Decorative Luminaires

- Acorn, globe, etc. The kit shall be tested, fully and properly mounted in a glass or polymer globe with optics as similar as possible to the kit’s intended use.
 - King Luminaire K400 series
 - Lexalite Lindy Model 424
 - GE Patriarch Luminaire
 - Holophane GV Luminaires Washington PostLite
 - Pre-approved Equivalent*
- Lantern. The kit shall be tested, fully and properly mounted in a glass or polymer lantern with optics as similar as possible to the kit’s intended use.
 - Architectural Area Lighting Civic Lantern Series
 - Acuity Lighting TR25
 - Pre-approved Equivalent*
- Teardrop, bullet, etc. The kit shall be tested, fully and properly mounted in a glass or polymer teardrop with optics as similar as possible to the kit’s intended use.
 - Holophane Port Huron
 - HE Williams OGL
 - Acuity Lighting (Antique Street Lamps) CM
 - Pre-approved Equivalent*

*The fixtures listed under “pre-approved equivalent” have been requested by applicants and approved for use in retrofit kit testing. Refer to [Retrofit Kit](#) policy for up to date pre-approved equivalents.

Outdoor Full-Cutoff Wall-Mounted Area Luminaires

- The kit shall be tested, fully and properly mounted in a fixture as similar as possible to the kit’s intended use.
 - Lithonia TWF1 100S
 - Pre-approved equivalent*

*The fixtures listed under “pre-approved equivalent” have been requested by applicants and approved for use in retrofit kit testing. Refer to [Retrofit Kit](#) policy for up to date pre-approved equivalents.

Note that at this time, DLC does not qualify screw-in "lamps" intended as HID replacements as retrofit kits.

Parking Garage

- The kit shall be tested, fully and properly mounted in a fixture as similar as possible to the kit's intended use.
- HID Reference Luminaires:
 - Lithonia VRC70ML 120/277 M6
 - Lithonia KACM Series Fixture
 - Cooper CL/CS Series Fixture
 - Pre-approved equivalent*
- Fluorescent Reference Luminaires:
 - LSI PGF Series
 - Lithonia VAP Series
 - GE VP8 Series
 - Columbia XEP Series
 - Pre-approved Equivalent*

*The fixtures listed under "pre-approved equivalent" have been requested by applicants and approved for use in retrofit kit testing. Refer to [Retrofit Kit](#) policy for up to date pre-approved equivalents.

Note that at this time, DLC does not qualify screw-in "lamps" intended as HID replacements as retrofit kits.

Fuel Pump Canopy

- The kit shall be tested, fully and properly mounted in a fixture as similar as possible to the kit's intended use.
 - LSI Scottsdale Series Fixture
 - Whiteway Civis Series Fixture
 - LSI Richmond Series Fixture
 - ElSCO Merritt Series Fixture
 - Pre-approved equivalent*

*The fixtures listed under "pre-approved equivalent" have been requested by applicants and approved for use in retrofit kit testing. Refer to [Retrofit Kit](#) policy for up to date pre-approved equivalents.

Note that at this time, DLC does not qualify screw-in "lamps" intended as HID replacements as retrofit kits.

2x2 Luminaires for Ambient Lighting of Interior Commercial Spaces

- The kit shall be tested, fully and properly mounted in a fixture as similar as possible to the kit's intended use.
 - Lithonia 2GT8 lensed 2X2
 - Lithonia 2SP8 lensed 2X2
 - Lithonia 2PM3 9 cell 2x2 parabolic
 - Cooper Metalux 2GC8 lensed 2x2
 - Cooper MetalUx 2HP3 9 cell 2x2 parabolic
 - Columbia Lighting lensed 4PS22

- Columbia Lighting P222 9 cell parabolic
- Pre-approved equivalent*

*The fixtures listed under “pre-approved equivalent” have been requested by applicants and approved for use in retrofit kit testing. Refer to [Retrofit Kit](#) policy for up to date pre-approved equivalents.

Please note that under the Technical Requirements V3.0 and higher, troffer retrofit kits will be categorized according to whether they are simple, “strip” style kits that replace the light source, but leave the existing troffer's optical system mostly intact, or whether they replace and retrofit the entire fixture, including a new optical system. For more information about these designations, please see the [Category Definitions](#) page.

1x4 Luminaires for Ambient Lighting of Interior Commercial Spaces

- The kit shall be tested, fully and properly mounted in a fixture as similar as possible to the kit’s intended use.
 - Lithonia GT8 lensed 1X4
 - Columbia Lighting lensed 4PS14
 - Pre-approved equivalent*

*The fixtures listed under “pre-approved equivalent” have been requested by applicants and approved for use in retrofit kit testing. Refer to [Retrofit Kit](#) policy for up to date pre-approved equivalents.

Please note that under the Technical Requirements V3.0 and higher, troffer retrofit kits will be categorized according to whether they are simple, “strip” style kits that replace the light source, but leave the existing troffer's optical system mostly intact, or whether they replace and retrofit the entire fixture, including a new optical system. For more information about these designations, please see the [Category Definitions](#) page.

2x4 Luminaires for Ambient Lighting of Interior Commercial Spaces

- The kit shall be tested, fully and properly mounted in a fixture as similar as possible to the kit’s intended use.
 - Lithonia 2GT8 lensed 2X4
 - Lithonia 2PM3N 12 cell 2x4 parabolic
 - Cooper Metalux 2GC8 lensed 2x4
 - Cooper Metalux 2HP3 12 cell 2x4 parabolic
 - Columbia Lighting lensed 4PS24
 - Columbia Lighting P224 12 cell parabolic
 - Pre-approved equivalent*

*The fixtures listed under “pre-approved equivalent” have been requested by applicants and approved for use in retrofit kit testing. Refer to [Retrofit Kit](#) policy for up to date pre-approved equivalents.

Please note that under the Technical Requirements V3.0 and higher, troffer retrofit kits will be categorized according to whether they are simple, “strip” style kits that replace the light source, but leave the existing troffer’s optical system mostly intact, or whether they replace and retrofit the entire fixture, including a new optical system. For more information about these designations, please see the [Category Definitions](#) page.

* Please note: DLC defines all tube-style products that use the lamp holders (i.e. sockets or tombstones) in the luminaire to mechanically or electrically connect to the fixture housing and electric supply to fall under the linear replacement lamps categories. Only retrofit products that do not connect to the troffer using lamp holders kits will be eligible under the retrofit kit categories.

Linear Ambient Luminaires

- The kit shall be tested, fully and properly mounted in a fixture as similar as possible to the kit’s intended use.
 - Strip-style Luminaires:
 - Columbia CS Bi-Pin 2L
 - Lithonia C2 32 MVOLT GEB10IS
 - GE UltraStar SR84230
 - Pre-Approved Equivalent*
 - Enclosed Linear Luminaires:
 - Lithonia VSL 2 32 MVOLT GEB10IS
 - Lithonia DMS2 48T8HO MVOLT GEB10PS
 - Pre-approved Equivalent*
 - Suspended Linear Luminaires:
 - Peerless LLML Suspended
 - Alera Lighting Microlyne M Cable Mount
 - Alcon Beam 44 Series 10107
 - Pre-approved Equivalent*
 - Wrap-style Luminaires:
 - Lithonia NEW 232
 - Lithonia 3324 217W and 3348 2L32W
 - Lithonia L8 217 and L8 232
 - Columbia AWN Series
 - Pre-approved Equivalent*

*The fixtures listed under “pre-approved equivalent” have been requested by applicants and approved for use in retrofit kit testing. Refer to [Retrofit Kit](#) policy for up to date pre-approved equivalents.

Note that at this time, DLC does not qualify screw-in “lamps” intended as HID replacements as retrofit kits.

High-Bay Luminaires

- The kit shall be tested, fully and properly mounted in a fixture as similar as possible to the kit’s intended use.

- HID Reference Luminaires:
 - Lithonia THD 400S A15 TB
 - Lithonia THR 400S PA22 TB
 - Pre-Approved Equivalent*
- Fluorescent Reference Luminaires:
 - Columbia LHC164-4
 - Columbia LHV4-4
 - Lithonia FGB Series
 - Lithonia MS8 Series
 - Pre-approved Equivalent*

*The fixtures listed under “pre-approved equivalent” have been requested by applicants and approved for use in retrofit kit testing. Refer to [Retrofit Kit](#) policy for up to date pre-approved equivalents.

Note that at this time, DLC does not qualify screw-in “lamps” intended as HID replacements as retrofit kits.

Low-Bay Luminaires

- The kit shall be tested, fully and properly mounted in a fixture as similar as possible to the kit’s intended use.

- HID Reference Luminaires:
 - Lithonia TXC 250S A23 TB
 - Lithonia TGR 175MP A125 TB SCWA
 - Pre-approved Equivalent*
- Fluorescent Reference Luminaires:
 - Lithonia L Series
 - GE Ultrastar ES Series
 - Pre-approved Equivalent*

*The fixtures listed under “pre-approved equivalent” have been requested by applicants and approved for use in retrofit kit testing. Refer to [Retrofit Kit](#) policy for up to date pre-approved equivalents.

Note that at this time, DLC does not qualify screw-in “lamps” intended as HID replacements as retrofit kits.

2. Option B: Testing in a Manufacturer-Selected Housing (Luminaire Specific)

DLC understands that not all retrofit kits are designed for the typical housings described above in Option A testing. If a retrofit kit is designed for a specific housing that is not represented by the approved housings listed above, and does not meet the conditions of the pre-approved equivalent process, manufacturers may select a different housing that is appropriate and representative of the housing the retrofit kit would be installed in the field.

Products tested via Option B are only considered qualified when installed in the specific housing used for testing. Additional testing in each housing will be required if manufacturers would like to have a retrofit kit considered qualified when installed in multiple housings under Option B. The spec sheet for the housing used for testing will be reviewed during the Initial Review process to ensure the housing is still within the intended use of the currently available retrofit kit Primary Use designations listed under the current [Technical Requirements Table](#).

DLC will determine if a retrofit kit is designed for a specific housing by reviewing the marketing material (i.e. product specification sheet) associated with the retrofit kit. Product specification sheets must clearly indicate for which specific housing the retrofit kit is intended. DLC reviewers may check web listing and other marketing materials, and reserve the right to request additional information to demonstrate the retrofit kit is only designed for a specific housing if product specification sheets are not sufficient.

Products tested according to Option B will be designated as “Luminaire Specific” on the QPL, with the housing used for testing listed in the Notes field.

Manufacturers shall test and report fixture performance under the following restrictions and conditions:

Required Tests & Reports

All DLC QPL testing and reporting requirements that apply to new fixtures shall also apply to any retrofit kit application e.g.: LM-79, ISTMT, IES file, TM-21 projection etc. (Note that for lumen maintenance testing, the source manufacturer is responsible for the LM-80 test of the LED package, array, or module. A report resulting from this test must be passed on to the DLC by the applicant, as specified in the application instructions.)

Fixture Level Tests

LM-79, ISTMT (or Option 2 lumen maintenance determination, if selected), shall be conducted in a fully functional manufacturer-selected reference fixture with the kit properly installed per manufacturer’s instructions.

Retrofit kits need to be tested in (i.e. supply an LM-79, ISTMT, IES file from testing in) only one of the fixtures approved, or pre-approved, below. The option you choose to use for [lumen maintenance](#) compliance will determine how many tests you need. If you choose Option 1: one LM-80 report and TM-21 projection is needed per LED package, array, or module as necessary according to the [multiple LEDs policy](#). If you choose Option 2: you will need to conduct luminaire-level testing of the retrofit kit installed in an approved fixture housing following the LM-84-14 test standard.

III. **Linear Replacement Lamps**

DLC DEFINES ALL TUBE-STYLE LED PRODUCTS THAT USE THE LAMP HOLDERS (I.E. "SOCKETS" OR "TOMBSTONES") IN THE LUMINAIRE TO MECHANICALLY OR ELECTRICALLY CONNECT TO THE FIXTURE HOUSING AND ELECTRIC SUPPLY TO FALL UNDER THESE TESTING REQUIREMENTS. PRODUCTS THAT DO NOT EMPLOY LAMP HOLDERS WILL BE CLASSIFIED AS RETROFIT KITS, REGARDLESS OF FORM FACTOR. PLEASE SEE DEFINITIONS PAGE AND TECHNICAL REQUIREMENTS TABLE FOR MORE DETAILS ON PRODUCT CLASSIFICATION.

DLC will accept QPL applications for U-Bend, Two-Foot, Three-Foot, Four-Foot, and Eight-Foot Linear Replacement Lamps.

UL Type B and C products marketed to replace T12 lamps (either solely or as a lamp intended to replace either a T8 or a T12) – are eligible in the 4-foot and 8-foot general applications. UL Type A lamps marketed to replace T12 are not eligible regardless of length or general application (including 4-foot and 8-foot). Lamps claiming to replace T12s in any other general application (2-foot, 3-foot, U-bend) are not eligible. Lamps marketed to replace any other designation of fluorescent lamp are not eligible.

One-lamp Type C TLEDs are eligible for qualification in all general applications within the Linear Replacement category. This includes T8 2-foot, 3-foot, 4-foot, and 8-foot replacement lamps, T5 and T5HO 4-foot replacement lamps, and U-bend replacement lamps.

Lamps which are marketed to operate utilizing magnetic ballasts are not eligible regardless of lamp category and type, and regardless of UL operation type.

Under the Technical Requirements Table V4.4, replacement lamps fall under one of the following General Application designations outlined below.

- T8 Two-Foot Linear Replacement Lamps: LED lamps intended to replace T8 fluorescent lamps. These LED lamps shall be 24 inches long and employ a G13 base. Marketing material shall indicate that they are intended to replace T8 fluorescent lamps of the same length. Products of different lengths and bases are not eligible under this general application. Products intended to operate on magnetic ballasts are not eligible.
- T8 Three-Foot Linear Replacement Lamps: LED lamps intended to replace T8 fluorescent lamps. These LED lamps shall be 36 inches long and employ a G13 base. Marketing material shall indicate that they are intended to replace T8

fluorescent lamps of the same length. Products of different lengths and bases are not eligible under this general application. Products intended to operate on magnetic ballasts are not eligible.

- **T8 Four-Foot Replacement Lamps:** LED lamps intended to replace T8 fluorescent lamps. These LED lamps shall be 48 inches long and employ a G13 base. Marketing material shall indicate that they are intended to replace T8 fluorescent lamps of the same length. Products of different lengths and bases are not eligible. Products intended to replace UL Type A T12 fluorescent lamps are also not eligible.
- **T5 Four-Foot Replacement Lamps:** LED lamps intended to replace T5 fluorescent lamps (note, not T5HO). These LED lamps shall be 46 inches long and employ a G5 base. Marketing material shall indicate that they are intended to replace T5 fluorescent lamps of the same length. Products of different lengths, bases, or marketed as intended to replace other types of fluorescent lamps are not eligible in this category.
- **T5HO Four-Foot Replacement Lamps:** LED lamps intended to replace T5HO fluorescent lamps. These LED lamps shall be 46 inches long and employ a G5 base. Marketing material shall indicate that they are intended to replace T5HO fluorescent lamps of the same length. Products of different lengths, bases, or marketed as intended to replace other types of fluorescent lamps are not eligible in this category.
- **T8 Eight-Foot Linear Replacement Lamps:** LED lamps intended to replace T8 fluorescent lamps. These LED lamps shall be 96 inches long and employ a FA8 base. Marketing material shall indicate that they are intended to replace T fluorescent lamps of the same length. Products of different lengths and bases are not eligible under this general application. Products intended to operate on magnetic ballasts are not eligible. Marketing materials may describe eight-foot T8 lamps as high output, as long as the eligibility and technical requirements are met, including base type.
- **U-Bend Replacement Lamps:** LED lamps intended to replace T8 fluorescent lamps. These LED lamps shall employ a G13 base. Marketing material shall indicate that they are intended to replace T8 fluorescent lamps of the same shape. Products of different bases are not eligible.

Under the Technical Requirements Table V4.4, replacement lamps fall under one of the following four Primary Use designations:

- **Replacement Lamps (UL Type A):**
 - Two-foot, three-foot, four-foot, eight-foot, and U-bend LED "tubes" designed to replace two-foot, three-foot, four-foot, eight-foot, and U-bend fluorescent lamps, respectively. Products in this category employ lamp holders to connect to the fixture being retrofitted and are designed to be "plug and play" replacements for fluorescent lamps. That is, products in this category can operate off an existing fluorescent ballast, and do not require mechanical or electrical changes to the fixture. Note that due to testing considerations, at this time only products that can operate off

specific ballasts types are eligible. Please see testing requirements below Replacement lamps designed to operate off magnetic ballasts, or off other types of electronic ballasts not specified, are not eligible at this time.

- **Internal Driver/Line Voltage (UL Type B) Lamps:**
 - Two-foot, three-foot, four-foot, eight-foot, and U-bend LED "tubes" designed to replace two-foot, three-foot, four-foot, eight-foot, and U-bend fluorescent lamps, respectively. Products in this category employ lamp holders to connect to the fixture being retrofitted, but do not operate off the existing fluorescent ballast. These products require rewiring of the existing fixture to bypass the ballast and send line voltage directly to the lamp holders.
- **External Driver (UL Type C) Lamps:**
 - Two-foot, three-foot, four-foot, eight-foot, and U-bend LED "tubes" designed to replace two-foot, three-foot, four-foot, eight-foot, and U-bend fluorescent lamps, respectively. Products in this category employ lamp holders to connect to the fixture being retrofitted, do not operate off the existing fluorescent ballast, and require rewiring of the existing fixture to replace the ballast with an external driver. The lamp holders are then wired to receive only the low-voltage electricity that is supplied by that external driver. Multi-lamp Type-C lamp systems are in general expected to have multiple lamps of the exact same type. For multi-lamp Type-C systems where the lamps within the system are not identical, please refer to the additional eligibility and testing requirements [below](#).
- **Dual Mode Internal Driver (UL Type A and Type B):**
 - Two-foot, three-foot, four-foot, eight-foot, and U-bend LED "tubes" designed to replace two-foot, three-foot, four-foot, eight-foot, and U-bend fluorescent lamps, respectively. Products in this category have the ability to operate off the existing fluorescent ballast and also have the ability to operate off of line voltage if the troffer is rewired to bypass the ballast. These products connect to the troffer using standard pin-base connections to the lamp holders. Note that due to testing considerations, at this time only products that can operate off specific ballasts types are eligible. Please see testing requirements below Replacement lamps designed to operate off magnetic ballasts, or off other types of electronic ballasts not specified, are not eligible at this time.

For testing purposes, DLC requires testing both of the bare lamp, and of lamps installed in a typical fixture housing. These typical fixture housings are intended to provide testing results of the most common applications these products are used in, as well as representative thermal conditions in the fixtures that the lamps would be installed in. In specifying these particular fixture housings, DLC does not endorse or exclude any particular make or model frame for use in energy efficiency programs.

In order for DLC reviewers to verify that the replacement lamp was tested in an Approved Housing, the housing used for testing must be clearly documented in the LM-79 and ISTMT reports submitted with the application. If the housing used for

testing is not clearly documented in the test reports, and the test reports cannot be updated with this information, DLC will require confirmation of the housing used for testing from the laboratory (ies) that conducted the testing.

Non-eligible Products

Products that are intended to function as two lamps combined together are not eligible for qualification at this time. This includes products with 4 pins at each end, as well as products which appear to be two lamps welded together. Below are some examples of products that are not currently eligible under the linear replacement lamp categories. See the image below for examples.

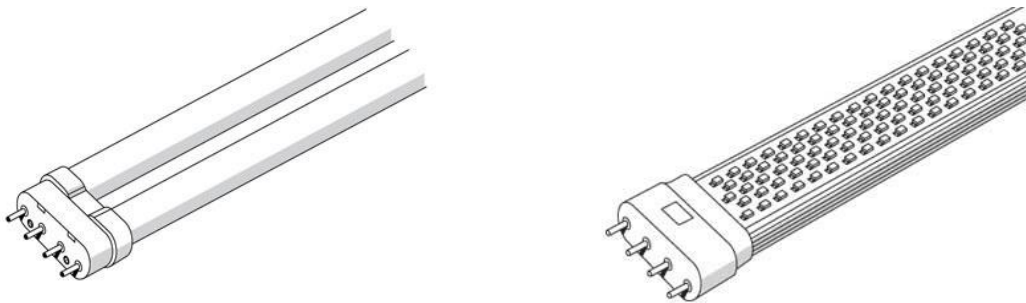

Lamps that require the use of specialized accessory components in order to meet the stated requirements are not eligible for qualification. The DLC reserves the right to ask for additional information regarding any components included in the testing with the product submitted, and deem a product not eligible for qualification.

Examples of specialized components that are not eligible include the use of socket extenders to shorten the distance between lamp holders and changing the lamp holders from G13-base to G5 base, or vice-versa. However, replacement of the existing fluorescent troffer sockets is allowed, and not considered a specialized component, if the replacement is specifically to change the lamp holders from shunted to unshunted, or vice versa, for safety compliance.

Applicants shall provide the following supporting documentation in addition to the test data described below.

1. Installation Instructions

Installation instruction sheets must be submitted with the application to indicate how the replacement lamp will be installed in an existing fixture in the field. This must be provided in addition to all necessary documentation required for other product categories. Lamps that require specialized components in order for installation to perform to the above criteria are not eligible for qualification. Lamps that employ rotatable end-caps are eligible, but must clearly indicate this feature in the product spec sheet.

2. Safety Certification Documentation

Documentation of safety certification for the replacement lamp must be submitted with the application. This documentation must indicate safety

certification has been obtained. DLC staff will not interpret safety testing as proof that safety certification has been obtained. This must be provided in addition to all necessary documentation required for other product categories.

3. Application Form Fields

For products intended to operate on regular Alternating Current systems, the “Minimum Input Voltage” and “Maximum Input Voltage” fields in the Application Form are intended to report the rated nominal AC input voltage range the product is designed to operate on. For UL Type A replacement lamps, these fields should be left blank, or indicated as “n/a”, as the input voltage is a property of the fluorescent ballast(s) the lamp is designed to operate on, and not of the lamp itself. For Dual Mode (UL Type A and B) products, these fields should record the AC voltage input range for which the product is designed to operate as a Type B replacement lamp.

4. Power Quality

Efficacy, power factor, and THD are calculated based upon the complete system required to install the product. The system may include an internal driver, an external driver, and/or an instant start ballast depending on the product submitted.

5. Application Review

DLC shall log, analyze and evaluate linear replacement lamp applications in accordance with procedures followed for any individual fixture application: 1) for completeness and accuracy of the filed application data and 2) for qualification according to DLC primary use specifications.

Applicants shall test and report performance under the following restrictions and conditions.

6. Special Considerations for Linear Replacement Type-C Lamp Systems with Non-Identical Lamps

Multi-lamp Type-C lamp systems are in general expected to have multiple lamps of the exact same type. For multi-lamp Type-C systems where the lamps within the system are not identical, the following restrictions and testing rules apply:

- Lamps within the Type-C system may only differ for purposes of allowing enhanced communications or control features. Lamps with explicitly different performance, such as nominally different color temperatures or light outputs, are not eligible to be listed in a Type C system.
- Lamp-level testing must show consistency between the two lamps in terms of light output, efficacy, and wattage within $\pm 10\%$. Products must also be of the same nominal CCT and CRI.

- Multi-lamp Type-C systems where the lamps within the system are not identical may only be submitted under Family Grouping applications. These products will not be eligible as “Single Product” applications.
- For the lamp-level testing, each of the distinct lamps in the system must have their own lamp level testing.
 - The appropriate number of multiple lamps *of the same type* should be loaded onto the driver, and lamp-level lamp testing conducted according to the [Testing Notes](#) sections below.*
- For the fixture-level testing, the system must be installed in the relevant reference housing as it is designed, sold, and intended to be installed in the field.
- All testing will be evaluated and must demonstrate that the products pass the requirements, including both lamp-level and in-fixture testing.
 - Due to the system-level testing configuration acceptability of Type C Linear Replacement Lamps, THD and Power Factor measurements will be accepted when measured inside the appropriate reference troffer if bare-lamp electrical testing is not available. Please note that this consideration only applies to Type C Linear Replacement Lamps, where more than one lamp is powered by a dedicated driver.
- QPL listings in the “Model Number” field must be of one of the following forms:
 - If each lamp and the associated driver in the system has a distinct product identifier (model number or other unique identifier), the distinct product identifiers will be noted in the model number field with the lamp quantity (“N”) for each lamp model in the system as: (Lamp A, Lamp B,... Lamp N)(Driver)
 - In a system with more than two lamps, model numbers will be represented as follows:
 - *Lamp A (one), Lamp B (“N”), (Driver)*
 - For example, a 4-lamp system will be represented as:
 - *Lamp A (one), Lamp B (three), (Driver)*
 - Alternatively, if the system is sold as one unified system under a single distinct product identifier, that identifier will be listed in the Model Number field: (System Ordering Code)
 - Test data and reported data on the QPL listing will reflect the worst-case efficacy lamp. A note placed in the Notes field will clarify that the data represents lamp-level data for the worst-case lamp in the system.

*Testing notes sections state the following regarding testing of multi-lamp type C systems. This has been the long-standing approach DLC has taken to these products:

“If the system is designed to operate multiple lamps utilizing an external driver, the driver should be loaded as it would be in the field, with appropriate steps taken to calculate the efficacy of the single lamp. For example, for a two-lamp kit, one lamp should be measured for light output, while the system as intended (with two identical lamps on the driver) should be measured for electrical input. The wattage into the driver can then be divided by two, and that wattage divided into the lamp lumens to determine system efficacy. For questions, please contact applications@designlights.org.”

7. Lamp Level Tests

Applicants shall test and report performance under the following restrictions and conditions. All lamps seeking qualification of the DLC must test the bare lamp according to LM-79

Individual Lamp Criteria							
	2-foot T8 replacements	3-foot T8 replacements	4-foot T8 replacements	4-foot T5 replacements	4-foot T5HO replacements	8-foot T8 replacements	U-bend T8 replacements
System Efficacy	≥ 110 lm/W	≥ 110 lm/W	≥ 110 lm/W	≥ 110 lm/W	≥ 110 lm/W	≥ 110 lm/W	≥ 110 lm/W
Initial Light Output	≥ 800 lm	≥ 1,200 lm	≥ 1,600 lm	≥ 1,600 lm	≥ 3,200 lm	≥ 3,200 lm	≥ 1,400 lm
CCT	≤ 5000K	≤ 5000K	≤ 5000K	≤ 5000K	≤ 5000K	≤ 5000K	≤ 5000K
CRI	≥ 80	≥ 80	≥ 80	≥ 80	≥ 80	≥ 80	≥ 80
Power Factor	≥ 0.90	≥ 0.90	≥ 0.90	≥ 0.90	≥ 0.90	≥ 0.90	≥ 0.90
THD	≤ 20%	≤ 20%	≤ 20%	≤ 20%	≤ 20%	≤ 20%	≤ 20%

8. Testing Notes

For T8 replacement lamps designed to operate off existing fluorescent ballasts, testing must be conducted using a standard 0.88 ballast factor, electronic instant-start ballast. Specification sheets for the ballasts used during testing must be provided with the application and the ballast make and model number must be noted in the test report. Ballasts used in testing must be certified to the applicable safety standards, and must comply with

applicable ANSI standards. Four-foot T8 replacement lamps must employ G13 bases and be nominally 48" long. Two-foot lamps must employ G13 bases and be nominally 24" long.

For T5 and T5HO replacement lamps designed to operate off existing fluorescent ballasts, testing must be conducted using a normal 1.0 ballast factor, electronic programmed-start ballast. Specification sheets for the ballasts used during testing must be provided with the application and the ballast make and model number must be noted in the test report. Ballasts used in testing must be certified to the applicable safety standards, and must comply with applicable ANSI standards. Four-foot T5 and T5HO replacement lamps must employ G5 bases and be nominally 46" long.

Product specification sheets must clearly indicate for which specific linear replacement lamp type (i.e. T8, T5, or T5HO) the product is intended, and list the nominal length in inches and base type.

For UL Type B and UL Type C Lamps, lamp-level testing is also required. If the system is designed to operate multiple lamps off an external driver, the driver should be loaded as it would be in the field, with appropriate steps taken to calculate the efficacy of the single lamp. For example, for a two-lamp kit, one lamp should be measured for light output, while the system as intended (with two identical lamps on the driver) should be measured for electrical input. The wattage into the driver can then be divided by two, and that wattage divided into the lamp lumens to determine system efficacy. For questions, please contact applications@designlights.org.

Fixture Level Tests: Two-Foot Linear Replacement Lamps

Please note that at this time lamps intended to replace T5-diameter fluorescents are only eligible in the four-foot categories. Only lamps intended to replace T8 fluorescents are currently eligible in the 2-foot categories.

All lamps seeking qualification must be tested inside in a reference troffer. Type A, Type B, and dual mode two-foot lamps shall test with three (3) lamps installed in an appropriate reference troffer. Type C lamps shall test with the appropriate number of lamps as are intended to be operated on the external driver included in that Type C system; 2-, 3, and 4-lamp Type C systems are eligible.

The reference troffer may be any of the following or a pre-approved equivalent:

- Lithonia 2GT8 lensed 2x2
- Lithonia 2SP8 lensed 2x2
- Lithonia 2PM3 9 cell 2x2 parabolic

- Columbia Lighting lensed 4PS22
- Columbia Lighting P222 9 cell parabolic
- Pre-approved equivalent*

In-situ Lamp Criteria for Two-Foot Linear Replacement Lamps	
Luminaire Efficacy (when 3 lamps are installed in reference troffer)	≥ 100 lm/W
Minimum Initial Luminaire Light Output (when 3 lamps are installed in reference troffer)	2 lamps installed 1,350 lm 3 lamps installed 2,000 lm 4 lamps installed 2,700 lm
Spacing Criteria	<u>Spacing Criteria:</u> 0-180° = 1.0 – 2.0 90-270° = 1.0 – 2.0 <u>Zonal Lumen Distribution:</u> 0-60°: ≥ 75%
Lumen Maintenance L70	50,000 hours

Pre-approved Equivalents

The DLC does not endorse or exclude any particular make or model of reference fixture. Options are listed to illustrate common fixtures of that type. With approval from the DLC, manufacturers may test in alternative fixtures. Pre-approved fixtures must meet the following conditions:

- Alternative fixtures must be commonly used in the application primary use intended to be applied for. Documentation may be required to demonstrate fixtures appropriate use if questions arise.
- Alternative fixtures must provide similar thermal environments to those listed. Particularly, alternative fixtures may not be significantly different in internal volume or construction materials.

Fixture Level Tests: Three-Foot Linear Replacement Lamps

Please note, at the time of this release, lamps intended to replace T5-diameter fluorescents are only eligible in the four-foot categories. Only lamps intended to replace T8 fluorescents are currently eligible in the 3-foot categories.

All lamps seeking qualification must be tested inside in a reference strip fixture. Type A, Type B, and Dual-mode three-foot lamps shall test with two (2) lamps installed in an appropriate reference fixture. Type C lamps shall test with the appropriate number of lamps as are intended to be operated on the external driver included in that Type C system; one-, two-, three- Type C systems are eligible.

The reference fixture may be any of the following, or a pre-approved equivalent:

- Lithonia C 2 25 MVOLT GEB10IS
- Lithonia Z 2 25 MVOLT GEB10IS
- Columbia CS3-225-EU
- Columbia CH3-225-EU
- Pre-approved equivalent

Pre-approved Equivalents

The DLC does not endorse or exclude any particular make or model of reference fixture. Options listed are intended to illustrate common fixtures of the appropriate type. Manufacturers may test in alternative fixtures to those listed, with pre-approval from the DLC. Pre-approved fixtures must meet the following conditions:

- Alternative fixtures must be commonly used in the application category intended to be applied for. Documentation may be required to demonstrate fixtures appropriate use if questions arise.

Alternative fixtures must provide similar thermal environments to those listed. Particularly, alternative fixtures may not be significantly different in internal volume or construction materials.

In-situ Lamp Criteria for Three-Foot Linear Replacement Lamps	
Luminaire Efficacy (when 3 lamps are installed in reference troffer)	≥ 100 lm/W
Minimum Initial Luminaire Light Output	2 lamps installed 2,200lm
Spacing Criteria	<u>Zonal Lumen Distribution:</u> 0-60°: ≥ 40%
Lumen Maintenance L ₇₀	50,000 hours

Fixture Level Tests: Four-Foot Linear Replacement Lamps

All T8 and T5 replacement lamps seeking qualification must be tested inside a reference troffer. Type A, Type B, and dual mode four-foot lamps shall test with two (2) lamps installed in an appropriate reference troffer. Type C lamps shall test with the appropriate number of lamps as are intended to be operated on the external driver included in that Type C system; 2-, 3-, and 4-lamp Type C systems are eligible.

The reference troffer may be any of the following, or a pre-approved equivalent:

- Lithonia 2GT8 lensed 2x4 (T8 replacements)
- Lithonia SP5 lensed 2x4 (T5 replacements)
- Lithonia 2PM3N 12 cell 2x4 parabolic (T8 or T5 version, as appropriate)
- Columbia Lighting lensed 4PS24 (T8 or T5 version, as appropriate)

- Columbia Lighting P224 12 cell parabolic (T8 or T5 version, as appropriate)
- Pre-approved Equivalent

Pre-approved Equivalents

DLC does not endorse or exclude any particular make or model of reference fixture. Options listed are intended to illustrate common fixtures of the appropriate type. Manufacturers may test in alternative fixtures to those listed, with pre-approval from the DLC. Pre-approved fixtures must meet the following conditions:

- Alternative fixtures must be commonly used in the application primary use intended to be applied for. Documentation may be required to demonstrate fixtures appropriate use if questions arise.
- Alternative fixtures must provide similar thermal environments to those listed. Particularly, alternative fixtures may not be significantly different in internal volume or construction materials.

In-situ Testing Requirements: Four-Foot Linear T8, T5, and T5HO Replacement Lamps		
	Four-Foot Linear T8 and T5 Replacement Lamps	Four-Foot Linear T5HO Replacement Lamps
Luminaire Efficacy (when 2 lamps are installed in reference troffer)	≥ 100 lm/w	≥ 105 lm/w
Minimum Initial Luminaire Light Output	2 lamps installed = 3,000 lm 3 lamps installed = 4,500 lm 4 lamps installed = 6,000 lm	3 lamps installed = 7,500 lm 4 lamps installed = 10,000 lm 6 lamps installed = 15,000 lm
Spacing Criteria	<u>Spacing Criteria:</u> 0-180° = 1.0 – 2.0 90-270° = 1.0 – 2.0 <u>Zonal Lumen Distribution:</u> 0-60°: ≥ 75%	<u>Zonal Lumen Distribution:</u> 20-50°: ≥ 30%
Lumen Maintenance L ₇₀	50,000 hours	50,000 hours

Fixture Level Tests: Eight-Foot Linear Replacement Lamps

All eight-foot T8 replacement lamps seeking qualification must be tested inside a reference strip fixture using an appropriate integrating sphere. Additionally, using a goniophotometer, a four-foot linear replacement lamp with identical construction as half of the eight-foot linear replacement lamp must be tested inside a reference strip fixture. Representative “identical” four-foot linear lamps must be a sellable product, with a distinct model

ordering number, that is marketed and produced by the same manufacturer. "Identical" linear lamps, while having the base type G13 as outlined in four foot lamp requirements, are defined as having the same type and quantity of driver(s), driving the LEDs at the same current, and having the same number of LEDs and PCBs as half of the eight-foot lamp. The representative lamp must also be of identical construction having identical cross-sections, the same tube material and thickness, and same heatsink material and extrusion. The goniophotometer testing results from the four-foot strip fixture shall be extrapolated to represent the eight-foot strip fixture by multiplying the candela of the four-foot goniophotometer output by a scale factor. That factor shall be derived through dividing the tested lumen output of the eight-foot strip fixture by the tested lumen output of the four-foot strip fixture, as obtained from the integrating sphere.

The results must meet the in-situ testing requirements in Table 5. Applicants must provide results from the eight-foot testing in the integrating sphere, the four-foot testing in the integrating sphere, and the four-foot testing in the goniophotometer. Product specification sheets for both the four-foot and eight-foot products must be submitted with the application. Applicant must also provide workflow demonstrating the calculation of the scale factor and identifying, within the photometric report, the candela values derived via calculation. In addition, a photo of the eight-foot and four-foot LED layout side-by-side, as well as a cross section diagram of construction for both products must be submitted.

Type A, Type B, and dual mode eight-foot lamps shall test with two (2) lamps installed in an appropriate reference strip. Type C lamps shall test with the appropriate number of lamps as are intended to be operated on the external driver included in that Type C system; one-, and two-lamp Type C systems are eligible.

The eight-foot reference strip may be any of the following, or a pre-approved equivalent:

- Lithonia C 2 96T8 MVOLT GEB10IS
- Columbia CS8-296T8-EU
- Saylite C 259 MV
- Pre-approved equivalent

The four-foot reference strip may be any of the following, or a pre-approved equivalent:

- Lithonia C 2 32 MV
- Columbia CS4-232-EU
- Saylite C 232 MV
- Pre-approved equivalent

4-foot Representative Fixture

The 4-foot representative fixture must be a genuine product marketed and produced by the same manufacturer and have a distinct model number. The LED board of your 4-foot fixture should have no variance in the quantity,

layout, or spacing of LEDs as half of your 8-foot fixture. The two lamps must also have the same type and quantity of driver(s) operating at the same drive current, and must also be of identical construction having identical cross-sections, the same tube material and thickness, and same heatsink material and extrusion.

Pre-approved Equivalents

The DLC does not endorse or exclude any particular make or model of reference fixture. Options listed are intended to illustrate common fixtures of the appropriate type. Manufacturers may test in alternative fixtures to those listed, with pre-approval from the DLC. Pre-approved fixtures must meet the following conditions:

- Alternative fixtures must be commonly used in the application category intended to be applied for. Documentation may be required to demonstrate fixtures appropriate use if questions arise.

Alternative fixtures must provide similar thermal environments to those listed. Particularly, alternative fixtures may not be significantly different in internal volume or construction materials.

In-situ Lamp Criteria for Eight-Foot Linear Replacement Lamps	
Luminaire Efficacy (when 3 lamps are installed in reference troffer)	≥ 100 lm/W
Minimum Initial Luminaire Light Output	2 lamps installed 6,000lm
Spacing Criteria	<u>Zonal Lumen Distribution:</u> 0-60°: ≥ 40%
Lumen Maintenance L70	50,000 hours

Fixture Level Tests: U-bend Replacement Lamps

Please note that at this time lamps intended to replace T5-diameter fluorescents are only eligible in the four-foot categories. Only lamps intended to replace T8 fluorescent U-bends are currently eligible in the U-bend categories.

All lamps seeking qualification must be tested inside in a reference troffer. Type A, Type B, Type C, and dual mode U-bend lamps shall test with two (2) lamps installed in an appropriate reference troffer.

The reference troffer may be any of the following, or a pre-approved equivalent:

- Lithonia 2GT8 lensed 2x2
- Lithonia 2SP8 lensed 2x2
- Lithonia 2PM3 9 cell 2x2 parabolic

- Columbia Lighting lensed 4PS22
- Columbia Lighting P222 9 cell parabolic

In-situ Lamp Criteria for U-Bend Replacement Lamps	
Luminaire Efficacy (when 2 lamps are installed in reference troffer)	≥ 100 lm/W
Minimum Initial Luminaire Light Output	2 lamps installed: 2,500 lm 3 lamps installed: 3,750 lm
Spacing Criteria	<u>Spacing Criteria:</u> 0-180° = 1.0 – 2.0 90-270° = 1.0 – 2.0 <u>Zonal Lumen Distribution:</u> 0-60°: ≥ 75%
Lumen Maintenance L ₇₀	50,000 hours

Pre-approved Equivalents

The DLC does not endorse or exclude any particular make or model of reference fixture. Options are listed to illustrate common fixtures of that type. With approval from the DLC, manufacturers may test in alternative fixtures. Pre-approved fixtures must meet the following conditions:

- Alternative fixtures must be commonly used in the application primary use for which the manufacturer intends to apply. Documentation may be required to demonstrate a fixture’s appropriate use.
- Alternative fixtures must provide similar thermal environments to those listed and may not be significantly different in internal volume or construction materials.

One-lamp Type C Linear Replacement Lamps

In addition to the lamp-level testing as specified, lamps must be tested in a reference luminaire. Applicants must test 1-lamp systems in one of the configurations listed in the relevant section of the policy. Specifically:

- Two-foot T8 replacement lamps must test with 2, 3, or 4 lamps installed in the reference luminaire
- Three-foot T8 replacement lamps must test with 2 or 3 lamps installed in the reference luminaire
- Four-foot T8 replacement lamps must test with 2, 3, or 4 lamps installed in the reference luminaire
- Four-foot T5 replacement lamps must test with 2, 3, or 4 lamps installed in the reference luminaire
- Four-foot T5HO replacement lamps must test with 3, 4, or 6 lamps installed in the reference luminaire
- Eight-foot T8 replacement lamps must test with 2 lamps installed in the reference luminaire

- U-bend T8 replacement lamps must test with 2 or 3 lamps installed in the reference luminaire
- Products should apply under, and will be listed on the QPL under, the primary use designation corresponding with the configuration of lamps used in reference luminaire testing. Single-lamp systems will note that they are single-lamp Type C systems under the “Notes” field in their listing information.

9. Lumen Maintenance

- LM-80 for the package/module/array (6,000 hours minimum)
- In-situ Temperature Measurement Test (ISTMT) in selected reference luminaire. Type A, Type B, Dual-mode and one-lamp Type-C lamps shall test with two (2) lamps installed. Type C lamps shall test with the appropriate number of lamps as are intended to be operated on the external driver included in that Type C system.
- TM-21 Calculator, appropriately filled out
(https://www.energystar.gov/sites/default/files/ENERGY%20STAR%20TM-21%20Calculator%20rev%2002-08-2016%20clean_0.xlsx)

10. Testing Notes

In order for DLC reviewers to verify that the retrofit kit or replacement lamp was tested in an Approved Housing, the reference housing used for testing must be clearly documented in the LM-79 and ISTMT reports submitted with the application. If the housing used for testing is not clearly documented in the test reports, and the test reports cannot be updated with this information, DLC will require confirmation of the housing used for testing from the laboratory(ies) that conducted the testing

For Replacement Lamps designed to operate off existing fluorescent ballasts, testing must be conducted using a standard 0.88 ballast factor, electronic instant-start ballast. Ballasts for each lamp length, including representative “identical” lamps, shall be determined for testing based on the appropriate ballast for installation with that lamp length. Specification sheets for the ballasts used during testing must be provided with the application and the ballast make and model number must be noted in the test report. Ballasts used in testing must be certified to the applicable safety standards, and must comply with applicable ANSI standards.

Replacement Lamps that utilize rotatable end caps should be tested in the orientation specified as the default in the manufacturer’s installation instructions. If the installation instructions do not specify an orientation, the lamps should be oriented “straight down” (this is commonly the “zero degree” setting). DLC reviewers will review the installation instructions provided with the application to verify the appropriate testing orientation, and compare this against documentation in the LM-79 report and IES file. Rotatable end cap

linear replacement lamp listings will include information on the testing orientation in the Notes field.

For UL Type B and UL Type C Lamps, lamp-level testing is also required. If the system is designed to operate multiple lamps off an external driver, the driver should be loaded as it would be in the field, with appropriate steps taken to calculate the efficacy of the single lamp. For example, for a two-lamp kit, one lamp should be measured for light output, while the system as intended (with two identical lamps on the driver) should be measured for electrical input. The wattage into the driver can then be divided by two, and that wattage divided into the lamp lumens to determine system efficacy. For questions, please contact applications@designlights.org.

IV. Screw-Base Replacements for HID Lamps

DLC will accept QPL applications for mogul (E39) screw-base replacement lamps. These product types remain under consideration for future development; "Type B" products (with internal drivers that operate directly off line voltage) and "Type C" products (with external drivers that replace the HID ballast in the circuit) are eligible (see [definitions](#)). Screw-Base Replacements for HID Lamps which incorporate functionality to allow a given model to produce multiple beam spreads/optical designs/distributions at or after the point of installation, are eligible under the [FALD Policy](#). The testing and reporting requirements described below are intended to subject the lamps to conditions in typical luminaires in order to assure confidence in performance.

For testing purposes, DLC specifies typical "reference" luminaire housings for lamp products to be tested in. This is done to provide testing results under common conditions that the lamps would be installed in. In providing this list of typical luminaire housings, DLC does not endorse or exclude any particular make or model frame for use in energy efficiency programs. Note that in each recommended variation we state, "or Pre-approved Equivalent." In selecting a luminaire for testing the applicant shall consider the purpose of subjecting the tested lamp to extreme confinement for thermal endurance. If a product demonstrates necessary performance in a given luminaire, the product will be considered qualified in that luminaire and in luminaires of similar types and applications, only. The product will not be considered generically qualified, nor qualified in other applications, unless the product is tested, demonstrates necessary performance, and is also listed on the DLC QPL in that application.

In order for DLC reviewers to verify that the replacement lamp was tested in an Approved Housing, the housing used for testing must be clearly documented in the LM-79 and ISTMT reports submitted with the application. If the housing used for testing is not clearly documented in the test reports, and the test reports cannot be updated with this information, DLC will require confirmation of the housing used for testing from the laboratory(ies) that conducted the testing.

Applicants shall test and report luminaire performance under the following restrictions and conditions:

Required Tests and Reporting

All DLC QPL testing and reporting requirements that apply to new luminaires shall also apply to any lamp application e.g.: LM-79, ISTMT, IES file, TM-21 projection etc. (Note that for lumen maintenance testing, the source manufacturer is responsible for the LM-80 test of the LED package, array, or module. A report resulting from this test must be passed on to the DLC by the applicant, as specified in the application instructions.) LM-79 reports for lamps should be submitted directly by the applicant to DLC.

Luminaire Level Tests

Lamps need to be tested in (i.e. supply an LM-79, ISTMT, IES file from testing in) only one of the luminaires approved above in section V.A.6. The option you choose to use for lumen maintenance compliance will determine how many tests you need. If you choose Option 1: one LM-80 report and TM-21 projection is needed per LED package, array, or module as necessary according to the [multiple LEDs policy](#). If you choose Option 2: you will need LM-84 testing and a completed ENERGY STAR TM-28 worksheet, with LM-80 testing and TM-21 projections as necessary.

Installation Instructions

Installation instruction sheets must be submitted with the application to indicate how the lamp will be installed in an existing luminaire in the field. These installation instructions must be the same ones provided to customers and installers in the market.

V. Hazardous Location Lighting

Products intended for Hazardous Locations are eligible for listing on the Qualified Products List. Under the V4.4 requirements version (as well as previous versions), they may qualify either within an existing Primary Use Designation, or by using the provisions for Specialty designations. Under this policy and V4.4, products seeking qualification on the QPL that would like to identify themselves as suitable for Hazardous Locations using the Specialty designations must provide documentation as described below to demonstrate the appropriateness of their products for Hazardous Locations. Products seeking qualification on the QPL using an existing Primary Use Designation do not need to provide additional documentation.

Hazardous Location Certification

In addition to all other requirements, products seeking qualification on the DLC QPL with "Hazardous" descriptor terms under a Specialty Primary Use Designation, including, but not limited to the following:

- Outdoor, Specialty: Hazardous Wall-Mounted Luminaire
- Outdoor, Specialty: Hazardous Area Lighting
- Outdoor, Specialty: Hazardous Flood/Spot Lighting
- Indoor High-Bay, Specialty: Hazardous High-Bay Lighting

Products seeking qualification must provide the Certification of Compliance, Notice of Authorization to Mark, or lab-specific directory listing from an applicable safety organization, explicitly stating that the model numbers in question are certified to the UL844 standard and including the Class and Division to which the products are certified. Testing must be performed by an appropriate safety organization in the US or Canada (i.e. OSHA NRTL or SCC-recognized body). DLC describes certification organizations that are acceptable for purposes of the DLC safety certification requirement in the Solid State Lighting [Safety Certification](#) section of the website.

In situations where questions arise, DLC will require that the documentation from the applicable safety organization clearly indicate both the models in question, and the certification to the UL 844 standard.

VI. Four Pin-Base Replacements for CFLs

DLC will accept SSL QPL applications for 4-pin (G24q/GX24q) replacement lamps and 2G11 base lamps greater than or equal to twenty inches. Both G24q-1, G24q-2, and G24q-3 and GX24q-1, GX24q-2, and GX24q-3 base types are eligible under either the Vertically- or Horizontally Mounted Four Pin-Base Replacement Lamps for CFLs General Applications. At this time, G24q/GX24q and 2G11 UL Type A lamps (designed to operate utilizing the existing CFL ballast), and 2G11 UL Type B (designed to operate utilizing direct line voltage), 2G11 UL Type C (designed to operate utilizing a non-integral driver), and 2G11 UL dual mode (designed to operate utilizing the existing CFL ballast or direct line voltage) are all eligible.

G24q or GX24q UL Type B lamps and UL Type C lamps, as well as products with other bases (including 2-pin products), remain under consideration for future development. Note that due to testing considerations, at this time only products that can operate utilizing specific ballast types are eligible (see testing requirements below). Replacement lamps designed to operate utilizing magnetic ballasts, or other types of electronic ballasts not specified, are not eligible at this time.

Four Pin-Base Replacement Lamps for CFLs that are capable of operating off both the existing ballast (UL Type A) and line voltage (UL Type B) are not eligible. Per the current policy, only "Plug and Play" (UL Type A) replacement lamps are eligible for qualification at this time.

The testing and reporting requirements described below are intended to subject the lamps to conditions found in typical luminaires to assure confidence in performance. For testing purposes, DLC specifies typical reference luminaire housings for lamp products to be tested in, as well as reference ballasts to be tested on. This is done to provide testing results under common installed conditions. In providing this list of typical luminaire housings and ballasts, DLC does not endorse any particular make or

model for use in energy efficiency programs. Note that in each recommended variation, it is stated, or “Pre-approved Equivalent.” In selecting a luminaire or ballast for testing, the applicant shall consider the purpose of subjecting the tested lamp to extreme confinement for thermal endurance, and electrical factors. For purposes of the 4-Pin-Base LED Replacement lamp category, if a product demonstrates necessary performance in a given pre-approved luminaire and reference ballast, the product will be considered qualified generally.

In order for DLC reviewers to verify that the replacement lamp was tested in an Approved Housing, the housing used for testing must be clearly documented in the LM-79 and ISTMT reports submitted with the application. If the housing used for testing is not clearly documented in the test reports, and the test reports cannot be updated with this information, DLC will require confirmation of the housing used for testing from the laboratory(ies) that conducted the testing.

Required Tests and Reports

All DLC QPL testing and reporting requirements that apply to new luminaires shall also apply to any lamp applications, e.g.: LM-79, ISTMT, IES file, TM-21 projection, etc. (Note that for lumen maintenance testing, the (LED) manufacturer is responsible for the LM-80 test of the LED package, array, or module. A report resulting from this test must be passed on to the DLC by the applicant, as specified in the application instructions. The report submitted to the DLC should be the most up-to-date report available for the LED package/module/array employed in the lamp.)

Pre-Approved Equivalent Luminaires

DLC does not endorse any particular make or model of reference luminaire. Options listed are intended to illustrate common luminaires of that type. Manufacturers may test in alternative luminaires to those listed, with pre-approval from the DLC. Pre-approved luminaires must meet the following conditions:

- Alternative luminaires must be commonly used in the application category intended to be applied for. Documentation may be required to demonstrate luminaires appropriate use if questions arise.
- Alternative luminaires must provide similar thermal environments to those listed below. Particularly, alternative luminaires may not be significantly different in internal volume or construction materials. Note: pre-approved equivalent requests will only be evaluated against the approved luminaires listed below. Evaluation will not be made against the list of pre-approved equivalents.

*A list of pre-approved equivalents will be along with the lists provided below, as requests are received and approved.

To request that a luminaire be considered as a pre-approved equal for testing purposes, please send the spec sheet for the luminaire to applications@designlights.org, along with a spec sheet for your lamp. DLC review staff may need additional details, depending on the request and details available in the spec sheet.

Pre-Approved Equivalent Ballasts

DLC does not endorse any particular make or model of reference CFL ballast. Options listed are intended to illustrate common reference ballasts for CFLs in the field. Manufacturers may test on alternative ballasts to those listed, with pre-approval from the DLC. Pre-approved ballasts must meet the following conditions:

- Alternative ballasts must be commonly used in operate CFLs in the intended field use. Documentation may be required to demonstrate ballast appropriate use if questions arise.
- Alternative ballasts must provide similar electrical conditions to those listed below. Particularly, alternative ballasts may not be significantly different in intended CFL operating wattage, ballast factor, efficiency, or power quality under similar loading conditions. Note: pre-approved equivalent requests will only be evaluated against the approved ballasts listed below. Evaluation will not be made against the list of pre-approved equivalents.

*A list of pre-approved equivalents will be along with the lists provided below, as requests are received and approved.

To request that a ballast be considered as a pre-approved equal for testing purposes, please send the spec sheet for the ballast to applications@designlights.org, along with a spec sheet for your lamp. DLC review staff may need additional details, depending on the request and details available in the spec sheet.

Luminaire Level Tests

LM-79 tests shall be conducted in a fully functional reference luminaire, and on an appropriate reference ballast, with the lamp properly installed per manufacturer's instructions. **Lamps need to conduct complete photometric testing in (i.e. supply an LM-79, IES file from testing in) only one of the luminaires approved below, and on only one of the reference ballasts specified.**

Photometric Testing: G24q/GX24q Base Lamps

Lamps seeking qualification must be tested in a reference downlight, based on the intended orientation of the lamp. Horizontally-mounted products must be tested two-lamps to a downlight, in an appropriate two-lamp reference downlight. Vertically-mounted products must be tested one-lamp to a downlight, in an appropriate one-lamp reference downlight.

Horizontally-mounted Lamp Reference Downlights:

- Lithonia 6HF 2/18DTT MVOLT
- Lithonia 6HF 2/26DTT MVOLT
- Prescolite LF6CFH 218 EB LCFH WT
- Prescolite LF6CFH 226 EB LCFH WT
- Or Pre-Approved Equivalent

Vertically-mounted Lamp Reference Downlights:

- Lithonia 6VF 18DTT/TRT MVOLT

- Lithonia 6VF 26-42TRT MVOLT
- Prescolite LF6CFV 32 EB LCFHV WT
- Or Pre-Approved Equivalent

Lamps must also be UL Type A (intended to operate on the existing CFL ballast only). Products must be tested on an appropriate one- or two-lamp reference ballast.

Horizontally-mounted Lamp Reference Ballasts:

- Philips ICF-2S18-HI-LD
- Philips ICF-2S26-HI-LD
- OSRAM/Sylvania QTP1/2x18CF/UNV
- OSRAM/Sylvania QTP1/2x26CF/UNV
- Triad C218UNVBE
- Triad C2642UNVBE
- Or Pre-approved Equivalent
 - GE GEC218-MVPS-3W
 - GE GEC226-MVPS-3W
 - Keystone KTEB-226-UV-PS-DW

Vertically-mounted Lamp Reference Ballasts:

- Philips ICF-2S18-HI-LD
- Philips ICF-2S26-HI-LD
- OSRAM/Sylvania QTP1/2x18CF/UNV
- OSRAM/Sylvania QTP1/2x26CF/UNV
- Triad C218UNVBE
- Triad C2642UNVBE
- Or Pre-approved Equivalent
 - GE GEC218-MVPS-3W
 - GE GEC226-MVPS-3W
 - Keystone KTEB-226-UV-PS-DW

Performance Requirements: G24q/GX24q Base Lamps

In-situ Testing Requirements: G24q/GX24q Base Lamps

In-situ Lamp Criteria for G24q/GX24q Base Lamps	
Luminaire Efficacy	≥ 65 lm/W
Minimum Initial Luminaire Light Output	Vertically-Mounted products: ≥ 575 lumens Horizontally-Mounted products: ≥ 800 lumens
Light Distribution	<u>Zonal Lumen Distribution:</u> 0-60°: ≥ 75%
Lumen Maintenance L ₇₀	50,000 hours

In-Situ Temperature Measurement Testing

Lamps must undergo *In-Situ Temperature Measurement Testing* (ISTMT) in the most restrictive thermal environment the product is rated for, per its safety certifications (UL/CSA 1993). TM-21 projections will use this thermal measurement in conjunction with the provided LM-80 data to evaluate lumen maintenance and compliance with L₇₀ requirements listed above.

Please note, this means if the product is certified to operate in a complete enclosed luminaire, ISTMT testing must be conducted in the appropriate reference enclosed UL apparatus. Accreditation requirements necessary for labs to conduct ISTMT testing may be found [here](#).

Lamp-Level Tests: G24q/GX24q Base Lamps

Due to the qualification approach for these products – qualified lamps are considered qualified as the lamp itself – DLC will list on the QPL lamp-level performance information.

Therefore lamps seeking qualification must test the bare lamp-ballast system according to LM-79.

Individual Replacement Lamp Criteria: **G24q/GX24q Base Lamps**

Individual Lamp Criteria (Bare Lamps)	
System Efficacy	≥ 75 lm/W
Initial Light Output	≥ 675 lm
Correlated Color Temperature (CCT)	≤ 5000K
Color Rendering Index (CRI)	≥ 80
Power Factor	≥ 0.90
Total Harmonic Distortion	≤ 20%
Warranty	≥ 5 Years

Lamps must also be UL Type A (intended to operate on the existing CFL ballast only). Products must be tested on an appropriate one- or two-lamp reference ballast.

Horizontally-mounted Lamp Reference Ballasts:

- Philips ICF-2S18-HI-LD
- Philips ICF-2S26-HI-LD
- OSRAM/Sylvania QTP1/2x18CF/UNV
- OSRAM/Sylvania QTP1/2x26CF/UNV
- Triad C218UNVBE

- Triad C2642UNVBE
- Or Pre-approved Equivalent
 - GE GEC218-MVPS-3W
 - GE GEC226-MVPS-3W
 - Keystone KTEB-226-UV-PS-DW

Vertically-mounted Lamp Reference Ballasts:

- Philips ICF-2S18-HI-LD
- Philips ICF-2S26-HI-LD
- OSRAM/Sylvania QTP1/2x18CF/UNV
- OSRAM/Sylvania QTP1/2x26CF/UNV
- Triad C218UNVBE
- Triad C2642UNVBE
- Or Pre-approved Equivalent
 - GE GEC218-MVPS-3W
 - GE GEC226-MVPS-3W
 - Keystone KTEB-226-UV-PS-DW

Note: If the system is designed to operate multiple lamps off the external ballast, the ballast should be loaded as it would be in the field, with appropriate steps taken to calculate the efficacy of the single lamp. For example, for a two-lamp system, one lamp should be measured for light output, while the system as intended (with two identical lamps on the ballast) should be measured for electrical input. The wattage into the driver can then be divided by two, and that wattage divided into the lamp lumens to determine efficacy. For questions, please contact applications@designlights.org.

Compatibility Tests: G24q/GX24q Base Lamps

Due to concerns of compatibility of LED lamps with the existing CFL ballasts, DLC will require that lamps undergo system-level testing on a variety of ballasts to demonstrate compatibility. *(Please note, that DLC may seek to evolve compatibility testing requirements as appropriate, based on experience and demonstrated need to assess products in the market.)* For V4.3, the DLC requires G24q and GX24q lamps seeking qualification to undergo testing as per the ENERGY STAR requirements for Frequency. These requirements are found Section 11.3 of [the ENERGY STAR Lamps V2.1 Specification](#), and are reproduced below for reference. Ballast compatibility testing is not currently required for 2G11 4 pin-base lamps. *(Please note that the DLC may seek to evolve compatibility testing requirements as appropriate, based on experience and demonstrated need to assess products in the market.)* Testing must be conducted at each end of the acceptable voltage range of the ballast.

Any variation that would affect electrical compatibility with the existing CFL ballast must be tested for compatibility. This means that wattage variations and dimming variations need compatibility testing, while CCT or optic (beam angle) variations do not. Feedback on the application of family grouping rules is welcome; please contact info@designlights.org.

Table 3: Compatibility Testing Requirements: G24q/GX24q Base Type Lamps

Requirement	Methods of Measurement and/or Reference Document	Testing Guidance
Lamp light output shall have a frequency of ≥ 120 Hz	Method of Measurement: None Reference Document: IEEE Std 1789™ – 2015	Sample Size: One unit per model Light output waveform shall be measured with a photodetector with a rise time of 10 microseconds or less, transimpedance amplifier and oscilloscope. Employed equipment models and method of measurement shall be documented. Temporal response, amplification and filtering characteristics of the system shall be suitably designed to capture the photometric waveform. Digitized photometric waveform data and an image of the relative photometric amplitude waveform shall be recorded. Measured data shall be recorded to a digital file with an interval between each measurement no greater than 0.00005 sec (50 microseconds) corresponding to an equipment measurement rate of no less than 20 kHz, and capture at least 1 second of data.

The lamp must be tested and results documented according to the above on each of the following ballasts:

- Philips ICF-2S18-HI-LD
- Philips ICF-2S26-HI-LD
- OSRAM/Sylvania QTP1/2x18CF/UNV
- OSRAM/Sylvania QTP1/2x26CF/UNV
- Triad C218UNVBE
- Triad C2642UNVBE
- Fulham NPY-120-226-CFL
- Howard EP2/26CF/MV/2
- Hatch HC226PS/UV/D
- Keystone KTEB-226-UV-RS-DW

Pre-approved equivalent requests will *not* be accepted for compatibility testing purposes.

Results of testing must be included in application materials submitted to DLC for evaluation. Products must pass criteria for all ballasts to qualify for listing on the QPL.

Testing must be conducted at a laboratory that is recognized by the ENERGY STAR program to conduct testing on LED replacement lamps (as listed in the ENERGY STAR directory, [here](#)).

Testing must be conducted at each end of the acceptable voltage range of the ballast.

All compatible ballasts must be clearly indicated on product marketing and installation literature. This documentation must be provided with the application for review.

Any variation that would affect electrical compatibility with the existing CFL ballast must be tested for compatibility. This means that wattage variations and dimming variations need compatibility testing, while CCT or optic (beam angle) variations do not. Feedback on the application of family grouping rules is welcome; please contact info@designlights.org.

Compatibility Documentation

All compatible ballasts must be clearly indicated on product marketing and installation literature. This documentation must be provided with the application for review.

Photometric Testing: 2G11 Base Lamps

Lamp Level Tests: 2G11 Base Lamps

Qualified 2G11 base lamps are considered qualified as the lamp itself. Due to this qualification approach for these products, the DLC will list on the QPL lamp-level performance information. Therefore, lamps seeking qualification must test the bare lamp-ballast system according to LM-79.

Table 4: Individual Replacement Lamp Criteria: 2G11 Base Type Lamps

Individual Lamp Criteria (Bare Lamps)	
System Efficacy	≥ 110 lm/W
Initial Light Output	≥ 1900 lm
Nominal Length	≥ 20"

Correlated Color Temperature (CCT)	≤ 5000K
Color Rendering Index (CRI)	≥ 80
Power Factor	≥ 0.90
Total Harmonic Distortion	≤ 20%
Warranty	≥ 5 Years

Products must be tested on an appropriate one- or two-lamp reference ballast:

- Philips ICN-1TTP40-SC
- Philips ICN-2TTP40-SC
- GE GEC140MAX-A
- GE GEC240MAX-A
- Osram QHE1X40DL/UNV/ISNSC
- Osram QHE2X40DL/UNV/ISNSC
- Or Pre-Approved Equivalent

In-Situ Temperature Measurement Testing

Lamps with a 2G11 base must undergo *In-Situ Temperature Measurement Testing* (ISTMT) in the most restrictive thermal environment the product is rated for, per its safety certifications (UL/CSA 1993). TM-21 projections will use this thermal measurement in conjunction with the provided LM-80 data to evaluate lumen maintenance and compliance with L₇₀ requirements listed in Table 4.

All 2G11 base lamps seeking qualification must be tested inside of a reference 2x2 lensed troffer. Types A, B, and Dual-mode lamps shall test with two (2) lamps installed in an appropriate reference troffer. The reference troffer and ballast must be included in the test report. Type C lamps shall test with the appropriate number of lamps as are intended to be operated on the external driver included in that Type C system.

The reference troffer may be any of the following:

- Lithonia 2GT8 lensed 2x2 CF40
- Lithonia 2SP8 lensed 2x2 CF40
- Lithonia 2PM3 9 cell 2x2 parabolic CF40

- Columbia Lighting lensed 2x2 4PS22 40TT
- Columbia Lighting P4D22-2 9 cell 2x2 parabolic 40TT
- Or Pre-Approved Equivalent

2G11 base lamps Type “A” (designed to operate utilizing the existing CFL ballast only) and Type dual mode (designed to operate utilizing the existing CFL ballast or direct line voltage) must be tested on an appropriate two-lamp reference ballast.

- Philips ICN-1TTP40-SC
- Philips ICN-2TTP40-SC
- GE GEC140MAX-A
- GE GEC240MAX-A
- Osram QHE1X40DL/UNV/ISNSC
- Osram QHE2X40DL/UNV/ISNSC
- Or Pre-Approved Equivalent

Table 5: In-situ Testing Requirements: 2G11 Base Lamps

In-situ Lamp Criteria: LED Replacement Lamps with 2G11 Base Types	
Luminaire Efficacy	≥ 100 lm/W
Minimum Initial Luminaire Light Output	2 lamps installed = 1,350 lm 3 lamps installed = 2,000 lm
Spacing Criteria	<u>Spacing Criteria:</u> 0-180° = 1.0 - 2.0 90-270° = 1.0 - 2.0 <u>Zonal Lumen Distribution:</u> 0-60°: ≥ 75%
Lumen Maintenance L ₇₀	50,000 hours

One-lamp Type C 2G11 Four Pin-Base Replacement Lamps for CFLs

In addition to the lamp-level testing as specified, lamps must be tested in a reference luminaire. One-lamp Type C 2G11 base lamps must test with 2 or 3 lamps installed in the reference luminaire.

Products should apply under, and will be listed on the QPL under, the primary use designation corresponding with the configuration of lamps used in reference luminaire

testing. Single-lamp systems will note that they are single-lamp Type C systems under the “Notes” field in their listing information.

Installation Instructions

Installation instruction sheets must be submitted with the application to indicate how the lamp will be installed in an existing luminaire in the field. These installation instructions must be the same ones provided to customers and installers in the market.

Safety Certification Documentation

Documentation of safety certification for the lamp must be submitted with the application. This documentation must indicate safety certification has been obtained. DLC staff will not interpret safety *testing* as proof that safety certification has been obtained. Please note that DLC qualification is not intended to imply that products are appropriate for use in specific applications outside the scope of their safety certification. Products used in violation of their safety certification would be considered not DLC qualified for use in that application by default.

Additional Requirements

- Products intended to mount horizontally must be axially rotatable (aimable).

V. Testing and Reporting Requirements for Modular Products with External Power Supplies

The DLC lists these products, when qualified, by unit with unit-level performance data for light output characteristics. The DLC understands that most refrigerator case lighting products are sold as systems with multiple units attached to a power supply. Individual units connected alone on the same power supply used in the system will not perform the same as they would when the total system is connected to the power supply because of efficiency variance based on the load on the power supply.

To obtain unit-level data that is accurate for an individual unit when installed in the system, the DLC would like testing conducted as follows:

- Each individual unit should be tested alone using the goniophotometer method according to LM-79 for light output and light distribution measurements. From this testing, the DLC will obtain the light output and light distribution (zonal lumen density) information.
- The worst-case system configuration should be tested (using either the integrating sphere method or goniophotometer utilizing a spectroradiometer method according to LM-79) for the other necessary metrics: efficacy, color, etc. The worst-case system will be the variation in your product line that would result in the lowest efficacy – typically at the worst (smallest) loading conditions for a given power supply – that you would sell as a new system commercially. The DLC will use this efficacy measurement to determine compliance with the DLC requirements.

The DLC will evaluate the individual unit efficacy as if it is equal to the system efficacy when the unit is installed in that system. In this way, the DLC will still be identifying unit-level data in the worst case scenario of a refrigerator case lighting system to evaluate against the unit-specific performance specifications. If the manufacturer chooses to provide another system configuration, a technical rationale of why the system exhibits the worst case efficacy must be provided. The technical rationale should be based on in-house data or other analysis.

Because refrigerator case lighting systems utilize external power supplies, manufacturers often use various power supplies or combinations of power supplies to attain the appropriate loads. Refrigerated case luminaire applications are held to the same driver variation policies detailed in the [Family Grouping policy](#).

VI. Testing and Reporting Requirements for Dimmable and Field-Adjustable Products

The DLC issued a new policy in March 2018 (as a part of Technical Requirements V4.3) that allowed products with field-adjustable light output capability to be qualified and listed on the SSL QPL. This beneficial product feature provides economies of scale opportunities for the supply chain, more flexibility for customers and installers, and additional energy-savings opportunities. In May 2018, the DLC suspended this policy in order to revise it to allow greater flexibility and clarity around the difference between field-adjustable and dimmable products and the associated testing requirements. With this V4.4 release, the DLC is issuing the revised policy. The revised policy simplifies the requirements and aligns testing requirements between dimmable and field-adjustable light output products.

Products with field-adjustable light output are eligible to be listed on the DLC Solid-State Lighting Qualified Products List (SSL QPL) under an expansion of the DLC Dimmable Products Policy.

Definition

Dimmable products, including field-adjustable light output products, are capable of being adjusted to increase and/or decrease lumen output and wattage from the default setting. The default setting is defined as the setting at which the product emerges from production and is shipped with no adjustments to lumen output.

Dimmable Eligibility

The following are eligibility rules for dimmable products.

- Dimmable products must meet all DLC Technical Requirements at the maximum light output setting.
- Dimmable products will only be classified as DLC Premium if they meet all [DLC Premium classification requirements](#) at the maximum light output settings.

Dimmable products may also be capable of color-tuning, and thus are subject to both the Dimmable Products Testing and Reporting Requirements and the [Color-Tunable Products Testing and Reporting Requirements](#).

DLC Members have expressed a need to be able to identify products that are able to dim with certain characteristics. The DLC now collects and reports specific dimming information to accommodate this need. For more information on how to report dimming information, please refer to the [guidance document \(pdf\)](#).

Dimming Types and Definitions

Applicants should use the following definitions of “Dimming Types” when answering application questions as to whether the product is continuously dimmable and/or field-adjustable.

- **Continuous Dimming** is defined by an input that controls the lighting system with sufficient resolution, in output of one hundred or greater steps, to support light level changes perceived as smooth. In contrast, stepped dimming controls the lighting system at a small number of discrete levels.
- **Field-Adjustable Light Output** is defined as a dimming type where products are capable of being adjusted to decrease or increase lumen output and wattage from the default setting. The default setting is defined as the setting at which the product emerges from production and is shipped with no adjustments to lumen output. The field-adjustable set point is fixed by the manufacturer, distributor, installer, or commissioning agent before or during installation or commissioning, via a control that is made discrete to that purpose via a proprietary process or separate control (i.e. not part of a regular occupant- or sensor-facing control system). Typically, the field-adjustable light output settings are not intended to be occupant interfacing.

Dimmable Products Testing and Reporting

DLC Single Product Applications may include dimmable products, including field-adjustable versions. Dimmable product submittals must include testing to demonstrate they meet DLC requirements at maximum light output. Additionally, the following information must be provided in the DLC application form (in the Scaled Performance Table tab):

- Is the product capable of dimming? The applicant will indicate “yes” or “no”.
- If the product is capable of dimming, how does the product dim? The applicant will indicate “continuous” or “stepped” dimming.
- If the product is capable of continuous dimming, is the product capable of dimming to 10% or below from its full input power when installed in an appropriate system? The applicant will indicate “yes” or “no”.
- Does the product provide field-adjustable light output? The applicant will indicate “yes” or “no”.
- If the product is capable of dimming, what is the default light output of the product? The applicant will indicate the value in lumens.
- If the product is capable of dimming, what is the default wattage of the product? The applicant will indicate the value in watts.
- If the product is field-adjustable, what is the minimum wattage of the product? The applicant will indicate the value in watts.
- If the product is field-adjustable, what is the maximum light output of the product? The applicant will indicate the value in lumens.

- If the product is field-adjustable, what is the minimum light output of the product? The applicant will indicate the value in lumens.

Verification of Dimming Type and Supporting Documentation

The DLC will evaluate manufacturers' claims of dimming capability by ensuring that the dimming claims are clearly published in the product specification sheet(s) and correspond with the unique model numbers submitted. The DLC will also evaluate the manufacturers' product installation instructions, including any supporting commissioning manuals, to determine eligibility. The installation instructions must be the same ones provided to customers and installers in the market. DLC reviewers may check web listings and other marketing materials and reserve the right to request additional information to demonstrate dimming capability if information in product specification sheets is not sufficient.

Note: Due to the lack of an industry standard testing methodology to verify dimming capability and performance under dimmed conditions, the DLC will not require testing be submitted to verify performance under dimmed conditions at this time.

Listing on the QPL

Dimmable products will be identifiable on the QPL as "Continuous Above 10%", "Continuous Below $\leq 10\%$ ", or "Stepped" within the existing fields: "Dimming Status" and "Dimming Type". If the dimmable products also have "Field-Adjustable Light Output" capability, they will be identified as such under the "Product Features" tab.

Dimmable products, including field-adjustable products, will be listed on the QPL at the maximum wattage setting, with the product performance characteristics from the LM-79 test: light output, power consumption, efficacy, THD, power factor, CRI, CCT, zonal lumens, spacing criteria. Additionally, field-adjustable products will list the reported default light output and default wattage, minimum and maximum reported light output, and minimum reported wattage. The maximum reported wattage field will not be used, as the regular reported wattage field is required to be at that maximum consumptive setting.

Products with distinct dimming types will be listed as separate entries on the QPL. For example, a product that is available in non-dimmable, continuously dimmable but not field-adjustable, and continuously dimmable AND field-adjustable versions will be evaluated and listed as three separate products.

Updating Dimmable Product Information

To update products already on the QPL with dimming information, including updates to add field-adjustable capability, the DLC provides a separate fee schedule as listed at <https://www.designlights.org/solid-state-lighting/submit-a-product/application-fees/>. Please visit <https://www.designlights.org/solid-state-lighting/submit-a-product/updating-products/> for more information on updating existing product listings.

VII. Testing and Reporting Requirements for Field Adjustable Light Distribution Products

Definition

Field-Adjustable Light Distribution (FALD) products are lamps, luminaires, or retrofit kits whose light distribution can be intentionally adjusted from the default factory “as-shipped” configuration. Light distribution is considered adjusted when the light intensity in one direction changes relative to the intensity in any other direction. FALD products eligible for listing on the SSL QPL fall into one or both of two types based on the method used to intentionally adjust their light distribution:

1. **Integral Field-Adjustable Light Distribution Products** – Products where the distribution can be adjusted by electrical or mechanical means without the addition, removal, or replacement of any parts or accessories. The adjustment must be integral to the product. For example, a luminaire with rotatable light bars to aim the light at different angles would fall under this category.
2. **Standard Component Field-Adjustable Light Distribution Products** – Products where the distribution is adjusted by adding or removing parts that are included with the product as sold under a single model number. These interchangeable components that come as standard with a single model number are defined as “Standard Components” for this policy. An example for this type of FALD product is a luminaire that is shipped standard with three reflectors under a single model number, and for which the installer chooses one of the reflectors during the installation and stores or discards the other two reflectors. *Products where the distribution is adjusted by adding parts that do not come standard with every order - termed “optional components” in this policy - are not considered FALD products and must be submitted under separate applications with separate model numbers for each component combination.*

The testing and listing requirements are identical for the two FALD types above, as described in the Eligibility, Testing and Reporting, and Listing sections below. SSL QPL applications for FALD products will be required to specify which of the two types above, or both, apply to the product.

Products with adjustable light output that do not incorporate adjustable distribution pattern are defined as dimmable and must comply with the [Testing and Reporting Requirements for Dimmable and Field-Adjustable Light Output Products](#).

FALD TYPE	INTEGRAL FALD PRODUCTS	STANDARD COMPONENT FALD PRODUCTS	PRODUCTS w/ OPTIONAL DISTRIBUTION -ALTERING COMPONENTS	PRODUCTS w/ BOTH INTEGRAL & STANDARD COMPONENT FALD	FALD PRODUCTS THAT MAY ALSO BE ORDERED WITH DISTRIBUTION-ALTERING OPTIONAL COMPONENTS
------------------	-------------------------------	---	---	--	--

DEFINITION	Products where the distribution can be altered by means integral to the product, electrical or mechanical	Products where the distribution is altered by adding or removing parts that are included with every product order under a single model number	Products where the distribution is altered by adding or removing optional parts not included with every product order	Products where the distribution is altered by both integral means and by means of standard components included under a single model number	Products with integral distribution adjustment, distribution-altering standard components, or both, but also available with optional parts that alter light distribution
EXAMPLE	Luminaire with rotatable light bars to aim the light at different angles	Luminaire that is shipped standard with three reflectors under a single model number; the installer chooses one of the reflectors during installation and stores or discards the other two reflectors	Luminaire that is available with 3 different shape reflectors with 3 model number variations for each reflector, and the customer chooses via the model number which one reflector is shipped with the luminaire	Luminaire that has both rotatable light bars <u>and</u> three reflectors under a single model number; the installer chooses one of the reflectors during installation and stores or discards the other two reflectors	Luminaire that is shipped standard with three reflectors under a single model number and the installer chooses one, and may be ordered with a optical shielding option to reduce intensity in one direction
Is it considered FALD & governed by this policy?	Yes	Yes	No	Yes	Yes, but: requires separate FALD applications for the shielded and unshielded variations

<p>Where must it meet the Technical Requirements for efficacy, light output, color, power quality, and ISTMT?</p>	<p>At the full range of the product's light distribution settings</p>	<p>At every combination of distribution-altering parts that are included standard under a single model number</p>	<p>Not FALD products: must be submitted for listing as separate application line items</p>	<p>At the full range of integral distribution settings with every combination of distribution-altering parts</p>	<p>At all integral adjustment settings for every combination of distribution-altering parts, separately for each optional party</p>
<p>Where must it meet ZLD Technical Requirements for Category and PUD?</p>	<p>At one manufacturer-designated setting</p>	<p>At one manufacturer-designated combination of distribution-altering parts that are included standard under a single model number</p>		<p>At one integral setting and combination of distribution-altering standard components</p>	<p>At one integral setting and combination of distribution-altering standard components, separately for each optional part</p>
<p>At what FALD setting will the light output, watts, efficacy, THD, power factor, CRI, CCT be listed</p>	<p>At the light distribution configuration that produces the worst-case efficacy performance, with product performance characteristics from that test</p>			<p>At the light distribution configuration that produces the worst-case efficacy performance</p>	<p>Listed separately for each optional part combination, at the distribution configuration that produces worst-case efficacy</p>

on the QPL?				
At what FALD setting will the ZLD distribution and spacing criteria be listed on the QPL?	At the manufacturer-designated light distribution setting or component combination submitted to meet the ZLD requirement		At the manufacturer-designated light distribution setting or component combination	Listed separately for each optional part combination, at the manufacturer-designated setting or component combination
How will it be identified on the QPL?	The QPL field for Product Features will list "Field Adjustable: Light Distribution"		The QPL field for Product Features will list "Field Adjustable: Light Distribution"	

Eligibility

The following are eligibility rules for FALD products:

- **All FALD Products** must meet all DLC Technical Requirements except Zonal Lumen Distribution (ZLD) for the Category and Primary Use Designation (PUD) under which they are being submitted across the full range of the product’s light distribution integral settings and standard components. This range includes all adjustment of either mechanical or electrical means including software-based methods, and all possible combinations of distribution-adjusting parts that are included standard under a single model number. If a Standard Component FALD product may be installed without any distribution-adjusting component attached, then the product must meet all DLC Technical Requirements for the Category and PUD under which is submitted both with and without any Standard Components.
 - **Exception to the above rule for evaluating light output of High Bay and Low Bay FALD products:** for both new luminaires and integrated retrofit kits within the High Bay General Application, products will be deemed to meet the DLC Technical Requirements for light output if they meet the DLC Technical Requirement for minimum and maximum light output for any Primary Use Designation within the High Bay General Application. Some PUDs—for example, High Bay Luminaires for Commercial and Industrial Buildings and Low Bay Luminaires for Commercial and Industrial Buildings—differ only in light output, with requirements above and below 10,000 lumens respectively. If field adjustment to the light distribution causes the light output of a High Bay product to cross below the 10,000-lumen threshold, that product shall still be eligible as long as it meets the light output requirement

of the Low Bay PUD, i.e. as long as it maintains light output above 5,000 lumens.

- **All FALD Products** must meet the DLC Technical Requirements for Zonal Lumen Distribution (ZLD) for the PUD under which they are being submitted at one light distribution setting of the manufacturer’s choosing, meaning at one integral adjustment setting and/or one combination of distribution-adjusting Standard Components. The product is not required to meet the ZLD requirements at other light distribution settings.
- **For Products that include both Integral FALD and Standard Component FALD**, the tested integral light distribution setting should be suitable for the intended use of each light distribution-adjusting component or accessory and need not be identical across all light distribution-adjusting accessories.
- **Products that include both FALD and Optional Components that adjust light distribution** - A product meeting the FALD definition above may also be offered with optional components or accessories that can be ordered separately or as an option within a unique model number for further adjusting its light distribution. Such product must be submitted as a separate application line item with a distinct model number for each distribution-adjusting component combination, each of which is treated as a FALD Product.
- **Listing a product under Multiple PUDs** - As with non-field-adjustable products, any product that can meet the Technical Requirements of multiple PUDs and for which the manufacturer seeks qualification and listing under multiple PUDs must be submitted on separate applications for each PUD with the necessary testing and application materials for each PUD it is to be listed under.
- FALD products will only be classified as DLC Premium if they meet all [DLC Premium classification requirements](#) for the Category and PUD under which they are being submitted.
- FALD products that fall under other DLC product Category and Primary Use eligibility rules, such as [Color-Tunable](#) or [Dimmable](#) products, are additionally subject to those respective Testing and Reporting Requirements. Please note that if the control that results in different distribution results in significantly different light output, provisions of the Dimmable and Field-Adjustable Light Output policy also apply.

Required Testing and Reporting

FALD products are only eligible to be submitted as “Family Grouping” DLC application types, and submittals must conform to the following testing rules in addition to the requirements of the family grouping policy.

Testing must be provided sufficient to bracket all products in the group per the DLC [family grouping requirements](#).

Required testing is summarized below, with the full requirements for each type of FALD Product described in detail below the table. For the purposes of this policy, the worst-case light distribution setting means the combination of the Integral FALD setting and the component combination for Standard Component FALD that together result in the worst or extreme value for the specified requirement.

Technical Requirement	FALD Testing Required
-----------------------	-----------------------

LM-79 Report Required:	<ul style="list-style-type: none"> • Worst-case efficacy • Maximum power consumption • Worst-case light output • Representative highest CCT • Representative lowest CCT • Representative lowest CRI
Bench Test Required:	<ul style="list-style-type: none"> • Worst-case power quality (THD & PF)
In-Situ Temperature Measurement Test (ISTMT) Required:	<ul style="list-style-type: none"> • Worst-case thermal condition • For Premium classification, worst-case driver thermal condition
Photometric Distribution data required:	<ul style="list-style-type: none"> • All optical variations excluding variations due to Integral FALD adjustability • One FALD setting designated for meeting ZLD requirements and listing on QPL

Required Testing

For all FALD products, testing shall be conducted in the light distribution settings that result in the worst-case performance for each of efficacy, wattage, lumen output, power quality, and thermal In-Situ Temperature Measurement Testing (ISTMT). The combination of product and FALD setting tested must result in the worst-case performance within the family for each tested value and may require testing at multiple FALD settings: up to three LM-79 tests, one power quality bench test, and two ISTMT tests.

1. LM-79 testing is required for the product and FALD setting combinations that represent the following worst cases:
 - a. The worst-case efficacy product and setting within the group
 - b. The maximum wattage product and setting within the group
 - c. The worst-case lumen output product and setting within the group
 - d. The worst-case power quality (THD, PF) product(s) and setting(s) within the group (may bench-tested)
 - e. Representative highest CCT
 - f. Representative lowest CCT
 - g. Representative lowest CRI
2. In-Situ Temperature Measurement Testing (ISTMT) is required for the product and FALD setting combination that results in the worst-case thermal condition.

3. If applying for Premium, ISTMT is required for the product and FALD setting combination that result in the worst-case driver thermal condition.
4. The Manufacturer shall provide photometric distribution data that meets the Zonal Lumen Distribution Requirements of the PUD for which it is being submitted in .ies file format.

Every family member must produce at least one photometric distribution that meets the PUD's ZLD requirements. Manufacturers will be required to identify the submitted .ies file that represents, for each family member, a relative photometric distribution that the family member can achieve. Each identified .ies file must meet the PUD's ZLD requirements. This IES-file-to-product correlation information shall be contained in a separate document, uploaded within the application portal, under the section in the "Documents" tab of the application titled "Additional Documentation Required for Field Adjustable Light Distribution (FALD) Products". Manufacturers may use the **DLC-provided template**, or their own reporting document, as they desire.

Additionally, the following information must be provided with the DLC application materials:

1. Is the product capable of field-adjustable light distribution? The applicant shall indicate in the application form, one of the following: "Integral FALD", "Standard Component FALD", "Integral and Standard Component FALD", or "No".
2. The manufacturer shall complete a new field in the application form describing the Adjustable Distribution Setting designated to meet the zonal lumen distribution requirement for the PUD. This description will be displayed on the QPL in a new text field.
3. The manufacturer shall describe in a separate document the adjustable setting position and/or the Standard Component combination that was used for each worst-case test submitted, and shall provide a written statement to justify why this setting and/or combination creates the extreme- or worst-case value in this test for each of the 8 requirements above (9 for Premium classification). The description and justification shall be provided for each test in this separate document, uploaded within the application portal. A separate document with justification is required even when the Integral distribution setting or Standard Component combination is also included in the test report. Please see note below for how to document the setting(s) with "aimable" products.

Note: All products where the light direction or intensity can change in the field, including "aimable" products like floods and track lights, are considered to have Field Adjustable Light Distribution as of March 7, 2019. For Flood and Spot Luminaires and Track or Monopoint Luminaires, where aimable capabilities are the norm, and where ZLD evaluation is relative to the center beam rather than to the environment, DLC will expect most technical justifications to describe that while the product is aimable, the characteristics of the beam are otherwise static, and therefore beam performance is expected to be nominally constant in different "settings" (aiming orientations). The application form should note these products as "Integral FALD" in the "Field Adjustable Type" column, and note the orientation they were in during goniophotometric testing in the "Adjustable Distribution Setting" column.

Supporting Documentation

The DLC will evaluate manufacturer's claims of FALD capability by ensuring that the adjustability claims are clearly published in the product specification sheet(s) and correspond with the unique model numbers submitted. The DLC will also evaluate the manufacturer's product installation instructions to determine eligibility. Documentation must include instructions for adjusting light distribution, including any required device or software. The instructions must be the same ones provided to the intended market actors or consumers who will be making the light distribution adjustments. DLC reviewers may check web listings and other marketing materials and reserve the right to request additional information to demonstrate capability if information in product specification sheets is not sufficient.

Listing on the QPL

FALD products will be identified as such under the "Product Features" tab on the SSL Qualified Products List (QPL) as either "Integral FALD", "Standard Component FALD", or "Integral and Standard Component FALD".

FALD products will be listed on the QPL at the light distribution setting that produces the worst-case efficacy, with the following product performance characteristics from that LM-79 testing at that setting: light output, watts, efficacy, THD, power factor, CRI, CCT.

The Zonal Lumen Distribution listing on the QPL for each family member will be calculated from the .ies file designated by the manufacturer as applicable to that family member.

The highest power consumption reported on the worst-case wattage LM-79 test will be listed on the QPL in the **Max. Tested Wattage** field for the tested family member. The highest power consumption provided for each family member on the application scaled performance table will be listed on the QPL in the **Max. Wattage** field.

- Note that the FALD policy states that products will be listed at the lowest-efficacy setting, while the Field Adjustable Light Output (FALO) policy states they will be listed at the highest output (most consumptive) setting. In the event a product falls under both FALD and FALO policies, and that the lowest efficacy setting and the maximum output setting are distinct, products will be generally listed at the lowest efficacy setting, with maximum possible wattage provided in the **Max. Wattage** fields (rated and tested, as appropriate).

A new text field, **Adjustable Distribution Setting**, will be added on the QPL for Integral FALD products to document the light distribution setting or Standard Component configuration designated by the manufacturer to meet the zonal lumen distribution requirement for the PUD.

Updating Listings

Historically, some product features that now fall under this policy – such as “aimable” products – were considered eligible before the implementation of the field-adjustable light distribution policy. These products will remain listed on the QPL and will default to **not** being noted as having field-adjustable light distribution unless the manufacturer takes action to update the existing listing as noted below.

Following the effective date of this policy, new submissions of products meeting the eligibility requirements of this policy will not be eligible for listing except under these field-adjustable provisions; the prior method for qualifying “aimable” products will not be available. Updates to products listed prior to 3/7/2019 will be allowed without meeting full submission provisions of this FALD policy.

Manufacturers who desire to update their “aimable” listings to reflect that their products are field-adjustable under the definitions in this new policy will be allowed to do so by submitting an update application, which requires spec sheets, installation instructions, a current application form, and any necessary testing to cover the products per the policies above. This update will be assessed an application fee per family group according to the individual characteristics of the update, including the number of additional tests needed to verify that the products pass all requirements.

- Per-test-report fees of \$500 per independent test report (ITR) evaluation required under the product group application procedure will only be charged for additional test reports that have not already been reviewed. (LM-79, LED ISTMT, and Driver ISTMT report types are considered ITRs.)
- Administrative updates to the listing will be charged update fees according to the **“dimming update” fee schedule**.

Products which were originally not presented as field adjustable, but which are seeking to update as field adjustable (for example, due to a design change), will be required to submit new, complete Family Grouping applications to update their listings.

The DLC may, in a future revision to the Technical Requirements, mandate that products that qualified prior to adoption of this policy be updated to current listing requirements.

Surveillance of FALD Products

When a FALD product is selected for surveillance, performance across the full range of adjustment and all combinations of Standard Components should meet DLC requirements at any tested position or Standard Component combination with exception to ZLD. The DLC may test the product(s) at up to 3 adjustment positions/settings or configurations, and the product must meet DLC requirements (excluding ZLD) for any tested position per this policy.

VIII. Testing and Reporting Requirements for Color-Tunable Products

Color-Tunable products are defined as products whose Correlated Color Temperature (CCT) can be adjusted via an input control of any type and whose chromaticity approximately follows the blackbody locus, providing white light at all input configurations. For this purpose, white light is defined as chromaticity coordinates within the twenty, 7-step quadrangles of ANSI C78.377-2017 Basic and Extended Specifications. Products supplying colored light (i.e. those capable of generating color points with Duv magnitudes beyond the limits of the ANSI Extended specification, also known as Full Color-Tunable) are outside the scope of these requirements and ineligible for listing at this time. White-Tunable products must utilize a control interface or multiple interface options clearly described in the product literature that allow for at least two CCT settings. These may be continuously-variable inputs such as a 0-10V DC signal, an established protocol such as DALI or DMX, a proprietary control signal, setting options described in terms of CCT such as 3000K or 5000K, or simple descriptive terms such as 'Night' or 'Day'.

Eligibility of Color-Tunable Products

Two types of products are eligible for listing as Color-Tunable:

1. **White-Tunable products** have a control signal specifically for adjusting CCT while maintaining nominally constant lumen output. These products may include a second, independent dimming control. White-Tunable products include both “white-white” products that combine the output of 2 LED primaries, and products with 3 or more white and/or RGB LED primaries, so long as they only produce white light as characterized above in response to their control signal.
 - White-Tunable products are not eligible to be submitted as Single Product Applications. Both single products and product families must submit a Family Grouping Application and meet all the [Family Grouping eligibility requirements](#). For the purposes of color tuning eligibility, the DLC’s existing requirements that a family must contain a “standardized set of LED packages/modules/arrays” and must demonstrate scalability or modularity using “any other applicable features” apply also to White-Tunable families, in that they must have identical chipsets and modular groupings of chipsets, resulting in an identical technological approach to color output.
 - The DLC requirements state that products within a family group of white-tunable products must have the same types of LEDs, and an identical technological approach to color output. This is intended to include a restriction that all products within a family group have the same tunable range. Therefore, as an example, if one version of a product can tune from 2700-5000K, while another version can tune from 2200-6500K, they must be submitted under separate applications, with independent testing.
 - White-Tunable products must meet the [DLC Technical Requirements](#) at all values of the color control signal for the General Application(s) and Primary Use(s) for which they are submitted, except for CCT. This includes minimum light output, efficacy, CRI, lumen maintenance, THD, Power Factor, and zonal distribution/spacing criteria requirements.
 - White-Tunable products must be capable of producing light at CCTs in alignment with existing maximum CCT limits for DLC qualified products.

- There are no color temperature limitations regarding the color-tunable feature for standard product listing on the QPL. However, the existing Technical Requirements specific to the product type must be met. For instance, outdoor products are not limited to a color temperature range but must be capable of light output at $\leq 5700\text{K}$ (per the nominal ANSI binning descriptions). Please consult the [Technical Requirements](#) for color temperature specific to the General Application and Primary Use Designation under which the product will apply.
- If a product has any functionality that enables it to change the color (i.e. CCT) of the emitted light, the intention is for it to be eligible under the requirements for color-tunable products. This includes products with a small set of color temperature settings controlled through mechanisms such as dipswitches set at the distributor or by the installer. Such products will not be deemed as non-color-tunable.
- White-Tunable products will only be classified as DLC Premium if they meet all [DLC Premium classification requirements](#) (except CCT) at all values of the color control settings. Additional documentation may be required.
- White-Tunable products may also have field-adjustable lumen output characteristics, in which case they are also subject to the [Field-Adjustable Product Testing and Reporting Requirements](#). If products exhibit both performance features, they must comply with both White-Tunable and Field-Adjustable Product Testing and Reporting Requirements.

2. Warm-Dimming products have a single input which controls both color temperature and lumen output, lowering the values of both concurrently, most typically to mimic the color temperature shift of incandescent dimming. Products that require on an external control system to coordinate dimming and warming color temperature are not eligible.

- Warm-Dimming products must meet all [DLC Technical Requirements](#), including CCT, for the General Application(s) and Primary Use(s) for which they are submitted, as measured at the maximum output for the product. The requirements include minimum lumen output, efficacy, CRI, CCT, lumen maintenance, THD, Power Factor, and zonal distribution/spacing criteria requirements.
- Warm-Dimming products do not need to meet DLC Technical Requirements at other input control settings, i.e. when they are dimmed below full output.
- Warm-Dimming products will only be classified as DLC Premium if they meet all [DLC Premium classification requirements](#) at the maximum input control setting.
- Warm-Dimming products may also have field-adjustable lumen output under the [Field-Adjustable Product Testing and Reporting Requirements](#), and thus be listed under both. If products exhibit both performance features, they must comply with both sets of requirements.

To be eligible for QPL listing, Color-Tunable products must meet either White-Tunable or Warm-Dimming requirements.

Listing on the QPL

Products will be identifiable on the QPL with either “White-Tunable” or “Warm-Dimming” values under a “Color Tuning” field.

White-Tunable products will be listed on the QPL at the least efficacious setting, with the corresponding product performance characteristics from that LM-79 test: Light Output, Power Consumption, Efficacy, THD, Power Factor, CRI, CCT, Zonal Lumens, Spacing Criteria. In addition, the QPL will display the Maximum Wattage, Minimum CCT, Maximum CCT, Minimum Light Output, and Maximum Light Output as separate fields.

Warm-Dimming products will be listed on the QPL at the full output setting, with the product performance characteristics from that LM-79 test: Lumen Output, Power Consumption, Efficacy, THD, Power Factor, CRI, Maximum CCT, Minimum CCT, Zonal Lumens, Spacing Criteria. Warm-Dimming products will be listed with only the CCT value corresponding to the full output setting.

Supporting Documentation Requirements

- **Control Interface Documentation**

Applicants shall provide the following supporting documentation with the application submittal. If any of the following information is not clearly documented in the product specification sheet or other supporting technical or marketing materials, the application will be considered incomplete and the DLC reviewer will request additional information.

- Description of the method of the input control, show photos of control input location and control input mechanism
- Reference to any control standards or protocols utilized
- Clear instructions for how to achieve the settings required in the testing section. Identical instructions must be provided to the test laboratory for testing and to the DLC during the application review.

Testing Requirements: White-Tunable Products

The testing for White-Tunable products must be provided to cover all areas of investigation as with non-color tuning family groups, plus additional testing across the color-tunable range for the least efficacious product.

White-Tunable product family submittals must include all testing reports required in this section. For White-Tunable products that also have an independent dimming control, testing must be conducted at the highest lumen output setting available for that CCT. For White-Tunable products with multiple control protocol options, testing must be conducted based on the most consumptive driver. For cases where provided test results do not appear to reflect the worst-case or setting required by this document, the DLC will require manufacturers to submit additional information and provide technical rationale to the DLC reviewer to support their case.

Based on consideration of the entire color input signal range for all members of the product family, the product family member with the lowest efficacy of any product-

and-color-control-setting combination in the group shall be LM-79 tested for all metrics other than distribution (IES files) at the following test points:

1. The **minimum CCT input control** setting
2. The **maximum CCT input control** setting
3. One **intermediate point**:
 1. For products with continuously variable input signals and those with input signals offering an odd number of discrete settings, the mid-point between the minimum and maximum CCT input signals or the middle setting
 2. For input signals with an even number of discrete settings, the lower of the two middle CCT input settings
4. Where none of the above tests result in the lowest efficacy condition, the **least efficacious** setting

If none of these test points represent 1) the minimum lumen output product-color-control-setting combination, 2) the minimum nominal CCT output, 3) the maximum nominal CCT output, 4) the minimum CRI, 5) the highest power consumption and 6) the worst power quality, then additional LM-79 testing shall be performed for whichever product-and-color-control setting combination within the group performs at the worst-case family-wide for:

5. Photometric distribution testing (goniophotometric testing) for a representative product for each optical variation within the group. This data must be submitted in IES file format and may be represented additionally in a PDF test report.
6. A test of the product at the color control setting that produces the lowest lumen output within the group
 1. For clarity, dimmable products shall NOT be tested in dimmed states. This is a required test of the product that produces the lowest lumen output of any product at any color control setting, at the maximum output dimming control setting
7. Where the minimum CCT is at least 100K less than the CCT produced at the minimum CCT input control setting, a test of a product at the **minimum CCT**
8. Where the maximum CCT is at least 200K greater than the CCT produced at the maximum CCT input control setting, a test of a product at the **maximum CCT**
9. A test of a product at the **minimum CRI**
10. A test of the product at the highest power consumption setting
11. Where none of the above tests result in the worst-case Power Quality applicant shall submit bench data documenting with the worst Power Quality (Power Factor and THDi)

In-Situ Temperature Measurement Tests (ISTMTs) must be provided on the following:

- Each LED package/module/array (i.e. each component for which LM-80 testing must be provided) at the worst-case thermal condition (worst-case product-setting combination) for that LED
 - It is expected that the worst-case condition for each LED type within a Color-Tunable product will necessarily be under different conditions. If LEDs are employed that have different LM-80s, multiple LED ISTMTs will be required.

- Each driver present in the product, at the worst-case thermal condition for that driver. (For products seeking premium qualification only.)
 - Again, if multiple drivers are used, this may result in the need for multiple driver ISTMTs, under different conditions.

LM-80 testing must be provided for each LED type present in the product. TM-21 projections must be provided for all LEDs at their measured ISTMTs.

- LM-80 applicability will be determined per the ENERGY STAR guidance, as per normal policies.

As part of the application submittal, manufacturers must report the power consumption for each ANSI C78.377-2017 CCT quadrangle from the minimum CCT to the maximum CCT, and for one reported CCT that falls between the quadrangle upper and lower limits. If discrete input control settings do not allow the product to provide light within the CCT range of a particular bin, manufacturers must provide the CCT and power consumption of the closest CCT to that range. If input control settings allow for more than one setting within an ANSI quadrangle, only the data for the setting that produces the actual CCT closest to the nominal CCT center point for the bin per the ANSI standard shall be provided. The data should be provided in the format of Table 1. The DLC will accept the following sources for self-reported/rated performance data.

1. **In-house laboratory test:** In-house test reports from tests conducted in accordance with IESNA LM-79
2. **Calculated Scaling:** Provide mathematical characterization of luminaire performance based on manufacturer-developed scaling methodology. The manufacturer must provide a description of the scaling methodology employed and the technical basis for its validity. The DLC reserves the right to accept or reject the methodology for use in qualifying products.

Data reporting format for white-tunable product submissions				
ANSI CCT Quadrangle (omit any outside product range) / Worst-Case Value	Actual CCT (K)	Power Consumption (W)	Lumen Output (lm)	Input Control Signal Applied
2200 K				
2500 K				
2700 K				
3000 K				
3500 K				
4000 K				
4500 K				

5000 K				
5700 K				
6500 K				
Lowest Efficacy				
Maximum Power				

Manufacturers can provide in-house testing on driver characteristics and zonal lumen output or other testing that might be necessary to support the designation of a least-efﬃcacious or highest-power-consumption control setting. As per normal, in-house testing informs selection of worst-case. Actual worst-case testing must be conducted per the appropriate test standard at an accredited lab.

Testing Requirements: Warm-Dimming Products

Warm-Dimming product submittals must include a single LM-79 report performed at the **maximum setting of the dimming input control**. If the LM-79 results fail to meet the Technical Requirements, the product will not qualify.

Other testing reports are required as per existing DLC policies for lumen maintenance and in-situ temperature measurement.

Manufacturers can provide in-house testing on driver characteristics and zonal lumen output or other testing that might be necessary to support the designation of a least-efﬃcacious or highest-power-consumption control setting.

The Family Grouping Testing Requirements apply to Warm-Dimming products in the same manner as with non-color tuning products.

IX. Testing and Reporting Requirements for DC/PoE Products

DC and PoE systems have the potential to reduce electrical losses from AC to DC conversions, integrate directly with DC generation sources such as solar and batteries, reduce installation costs, and connect more readily to IT infrastructure for advanced lighting control. These Requirements for DC and PoE Products enable high quality DC and PoE lighting products to be qualiﬃed and listed on the DLC SSL QPL.

Products powered by Direct Current (DC) and Power over Ethernet (PoE) must comply with the provisions of this document to be eligible for listing on the DLC Solid-State Lighting Qualiﬃed Products List (SSL QPL). DC/PoE products are deﬃned as SSL lamps, luminaires, and retrofit kits that are powered by a DC voltage. PoE products are a speciﬃc subset of DC products that comply with the IEEE 802.3 Standards for carrying both power and communication signals on Ethernet cables. Qualiﬃed products will be listed as DC or PoE products on the DLC SSL QPL. If DC/PoE lamps, luminaires, and retrofit kits are also capable of being powered by Alternating Current (AC) voltage and the manufacturer desires to have them listed as suitable for both AC and DC, then the AC listing of the product must have a distinct model number that is different from the DC listed product, and it must be separately

qualified.

The DLC lists DC/PoE lamps, luminaires, and retrofit kits on the SSL QPL based only on the luminous efficacy of these products as measured at their DC power input. The overall energy consumption of the DC/PoE systems also depends on DC line losses and DC power source efficiency, in addition to luminaire or lamp efficacy. However, given the variation in system architectures and power losses, the DLC does not publish system-level efficacies for DC/PoE SSL products. The DLC has developed a separate document to be provided to utility and energy efficiency program administrators that will provide basic guidance for accounting for system losses of DC/PoE SSL products.

Definitions

The following are definitions associated with DC/PoE products:

1. **DC Power Source:** In this policy, the term “DC Power Source” is used to indicate the device(s) that connect AC mains to the lines directly providing DC input power to the DC/PoE product. Though DC/PoE products may be used entirely disconnected from the AC power grid, the primary focus of this policy is grid-connected SSL lighting. A DC Power Source may be more typically known as any of the following:
 - **AC-to-DC Power Converter**
 - **Power over Ethernet Power Sourcing Equipment (PoE PSE)**, also known as a PoE Switch
 - **AC/DC Multi-Directional Inverter**
2. **DC-to-DC Driver:** An LED driver that is typically integrated into the luminaire that converts the DC voltage received at the DC luminaire into the DC voltage required to operate the LEDs in the lamp, luminaire, or retrofit kit. Not all DC/PoE lamps, luminaires or retrofit kits require a DC-to-DC driver.

Eligibility

The following are eligibility rules for DC/PoE products:

- DC/PoE products are only eligible to be submitted as “Family Grouping” DLC application types and must be tested in accordance with the requirements of the family grouping policy. This applies to both single DC/PoE products and DC/PoE product families.
- DC/PoE products must meet all DLC Technical Requirements for the General Application(s) and Primary Use(s) they are submitted for, including minimum lumen output, efficacy, correlated color temperature (CCT), color rendering index (CRI), lumen maintenance, and zonal distribution/spacing, with the exception of total harmonic distortion (THD) and power factor.
- Products marketed or intended for use disconnected from the AC power grid are eligible for listing on the SSL QPL. However, if applicable, eligibility of these products for efficiency program incentives/rebates is at the discretion of efficiency program administrators and should not be assumed based only on QPL listing.
- Linear replacement lamps, mogul screw-base replacement lamps, and 2G11-based replacement lamps for CFLs are only eligible for listing as DC/PoE products if they are UL Type C products. A Type C DC/PoE replacement lamp must utilize DC voltage

as the input to the remote driver; replacement lamps utilizing DC voltage only between driver and lamp are eligible as AC products, not DC/PoE products.

- DC/PoE luminaires will only be classified as DLC Premium if they meet all DLC Premium classification requirements. An LED Driver ISTMT is required for DLC Premium submissions of luminaires with an integrated DC-to-DC driver. Additional documentation is required for the driver per the requirements for Premium luminaires.
- DC/PoE products may also have other eligible adjustable product features for AC products, such as Color-Tuning and Dimming, in which case they are also subject to the relevant DLC Testing and Reporting Requirements for those types of products. If products exhibit multiple performance features, they must comply with all applicable Testing and Reporting Requirements.

Testing Methods and Requirements

Testing for DC/PoE products must be provided to cover all areas of investigation as is required for AC family groups. Per the eligibility criteria above, **all DC/PoE products must be submitted as a Family Group**, regardless of the number of products submitted. The below requirements apply to the DC/PoE luminaire, lamp, or retrofit kit under consideration, as test reports will not be required on the DC Power Source.

1. The DC/PoE product or group of products shall be tested according to the guidelines for electrical instrumentation of DC devices in the Illuminating Engineering Society's (IES) LM-79 publication.
 - a. The intent of the LM-79 test reports required for DLC submission is measurement of the luminaire efficacy as well as other photometric characteristics under DC power without including DC Power Source conversion losses or line losses.
 - b. Many DC/PoE products, for example PoE, utilize cables with multiple conductors. LM-79 test reports shall be based on the sum of all power delivered to the product across all connected conductors. The test report shall document the number of powered conductors, and pair-wise grouping if applicable.
 - c. Voltage and current measurements shall be made at the point of entry to the luminaire or retrofit kit, or at the input terminals to the driver in the case of UL Type C replacement lamps. For luminaires and retrofit kits, these measurements shall include any DC-to-DC driver circuitry that is included and shipped under the same model number as the luminaire or retrofit kit, but exclude drivers that need to be ordered separately under a different model number. For UL Type C replacement lamps, these measurements shall include the remote DC-to-DC driver circuitry. If the test laboratory is in doubt about the proper interconnection or placement of voltage sensing leads for power measurement, they should consult the manufacturer.
 - d. Test laboratories should connect measurement equipment in such a manner that creates minimal disruptions to data communication if the DC power connection carries both data and power. Manufacturers should, if necessary, provide testing labs with instructions for achieving a state of full light output without the consumption of unnecessary communication power.
 - e. Any removable accessories not required to achieve full light output, such as removable photosensors or occupancy sensors, shall be removed during LM-

- 79 testing. Any accessories with controllable power states that are not required to achieve full light output, such as cameras, microphones or external luminaire power connections, shall be disabled/powered down during LM-79 testing.
2. The luminous efficacy according to the LM-79 test method shall be provided at two voltages:
 - a. *The DC input voltage that results in the worst-case luminous efficacy.* The tested voltage must result in the worst luminous efficacy across the product's operating range of input voltage. The product's voltage range is determined based on the information in the manufacturer's specification sheets and, if applicable, within the input voltage range of the established system protocol (e.g. between 42.5V and 57V for IEEE 802.3at Type 2 PoE powered devices). For any application where the worst-case submitted voltage is not the lowest voltage in the operating range, the manufacturer must submit a written justification explaining why their product performs at lower luminous efficacy at the higher input voltage. This justification must be in a formal document submitted through the DLC Application Portal. Verbal explanations, emailed explanations, or explanations written into the Portal messaging system will be requested to be formally written and submitted.
 - b. *A nominal DC voltage chosen by the manufacturer.* The nominal DC voltage chosen must be within the product's operating range of input voltage according to the manufacturer's specification sheets or system documentation, and, if applicable, within the input voltage range of the established system protocol (e.g. between 42.5V and 57V for IEEE 802.3at Type 2 PoE powered devices) and less than any maximum voltage permitted under the National Electrical Code for the wiring and power specified (e.g. NEC maximum of 60V for Class 2 above 5 mA). The nominal voltage shall be different from the worst-case voltage from section (a) above.
 3. Manufacturers must provide instructions to the testing laboratory for how to achieve the full light output state for LM-79 testing. Full light output state is defined as the light output state where the product is delivering its maximum lumen output, with any dimming input control signal set to the maximum setting.
 4. In-Situ Temperature Measurement Tests (ISTMTs) must be conducted as defined by the appropriate safety standard, per applicable safety certifications. TM-21 projections will use this thermal measurement in conjunction with the provided LM-80 data and rated drive current to evaluate lumen maintenance and compliance with L₇₀ requirements. Alternatively, LM-84 testing and TM-28 projections will be acceptable. Please contact info@designlights.org if you intend to use this alternative LM-84 approach.

Supporting Documentation

Applicants shall provide the following supporting documentation for DC/PoE products. If any of the following information is not clearly documented in the installation guide, product specification sheet, or other supporting technical or marketing materials, the application will be considered incomplete and the DLC reviewer will not proceed in reviewing the application until the necessary information is provided.

- **Product Installation, Power Source, and Wiring documentation** covering the following:
 - Nominal input voltage to luminaire, lamp or retrofit kit, when applicable

- Range of acceptable input voltages to luminaire, lamp, or retrofit kit
- List of compatible DC Power Source models and/or parameters for choosing compatible DC Power Sources
- List of compatible cable models, and/or parameters for choosing wiring gauge and type
- Where applicable, reference to standard compliance and relevant product subcategories/classifications
- For PoE products, reference to IEEE 802.3af/at/bt standard compliance, PoE type, and device class
- **Safety Certification**
 - The requirements for safety certification of DC/PoE products are the same as the **safety provisions listed for AC products**.

Listing on the QPL

The DLC intends to list DC/PoE lamps, luminaires, and retrofit kits on the SSL QPL based only on the luminous efficacy of these products as measured at their DC power input. DC/PoE products are listed on the SSL QPL according to their worst-case efficacy as documented in the LM-79 report(s) specified in Section 2a of the Testing Requirements above. All existing QPL fields apply to DC/PoE products except for total harmonic distortion (THD) and power factor (PF). These two fields are either left blank or "N/A". DC/PoE products are distinguished from AC products on the SSL QPL as follows:

- DC/PoE listings on the QPL will prominently feature and point to a supplemental guide or pop-up window that provides important information for how to use the DC/PoE listing data, which is different from non-DC/PoE listing data.
- Five new fields have been created for DC/PoE listings, two of which are exclusively applicable to PoE, and one existing field has been modified:
 - **"System Type"**. This new field applies to all products on the QPL and is populated with text as "AC", "DC", or "PoE".
 - **"Test Voltage"**. This new field is required for DC and PoE products and may also be applied to existing AC products. It is a numerical value that lists the voltage from the LM-79 test report (e.g. 24 Volts, 380 Volts, etc.) that corresponds to the worst-case luminous efficacy listed for that product.
 - **"Voltage Range"**. This new field applies to both AC and DC products, and lists the range of acceptable input voltage for the product (e.g. 120-277VAC, 44-57VDC).
 - **"DC Efficacy"**. This new field lists the worst-case efficacy of DC/PoE products, which is different from the current "Efficacy" field for existing products. The existing "Efficacy" field on DLC QPL has been changed to "AC Efficacy" to clearly differentiate from the "DC Efficacy" of DC/PoE products.
 - **"PoE Type/Class"**. This new field is only applicable to PoE products and lists the Type and Class of PoE utilized.
 - **"PoE Connection"**. This new field is exclusively for PoE products to indicate whether the product connects directly or indirectly to the PoE network; for example, whether a luminaire connects directly to the PoE network, or indirectly through another luminaire or driver that is connected to the PoE network.

X. Laboratory Requirements

The DLC requires that product testing be conducted at a laboratory appropriate for the performance being evaluated. Laboratories must be approved or accredited by organizations knowledgeable of the appropriate testing conditions, testing equipment, and staff competencies necessary for accurate measurements. Below are details regarding the accreditation requirements of a laboratory for each of the test methods described in the [Understanding Testing Principles](#) section.

The DLC does not endorse any laboratory meeting these requirements. Laboratories representing the ability to qualify products and laboratory test reports indicating product performance meets DLC Technical Requirements do not represent official DLC product qualification. All decisions regarding product qualification are made by the DLC. DLC reviewers reserve the right to request documentation confirming testing conditions or to confirm testing has been conducted by a laboratory that meets these requirements at the time of testing.

Test Laboratory Requirements As of March 21, 2018	
In-situ Temperature Measurement Test (ISTMT)*	<p>DLC will accept ISTMT results from laboratories meeting at least one of the following requirements:</p> <ul style="list-style-type: none"> • Approved by OSHA as Nationally Recognized Testing Laboratories (NRTLs). To find a list of OSHA NRTLs, visit: https://www.osha.gov/dts/otpca/nrtl/ • Approved through an OSHA NRTL data acceptance program or OSHA Satellite Notification and Acceptance Program (SNAP). • Accredited for ANSI/UL 1598 or CSA C22.2 No. 250.0-08, including Sections 19.7, 19.10-16, by an accreditation organization that is an ILAC-MRA Signatory. <p><i>*Note these requirements are applicable to laboratories conducting both LED ISTMTs and Driver ISTMTs</i></p> <p>UL 1598 testing may be used for the ISTMT report if the lab that conducted the test meets the DLC’s laboratory requirements for ISTMT.</p>
LM-79	<p>The DLC will accept LM-79 results from laboratories that comply with the DLC LM-79 Testing Lab Requirements. Testing must be conducted and reports must be issued within the accreditation effective and expiration dates detailed for a given laboratory.</p>

	The list of DLC Approved LM-79 Testing Laboratories can be found here .
LM-80	<p>DLC will accept LM-80 results from laboratories listed as EPA-Recognized Laboratories for LM-80.</p> <p>Note: DLC refers to ENERGY STAR Requirements for the Use of LM-80 Data when determining applicability of LM-80 data for submitted products.</p> <p>To find the list of EPA-Recognized Laboratories for LM-80, visit https://data.energystar.gov/dataset/EPA-Recognized-Laboratories-For-Lighting-Products/jgwf-7qrr, and filter the "Area of Recognition" column by "LED package, module or array (IES LM-80-15)."</p>

The Testing Laboratory Requirements above are effective as of March 21, 2018. Manufacturers may submit testing conducted at a laboratory meeting these requirements in support of a DLC product application at any time moving forward.

In addition to the Testing Laboratory Requirements above, as of July 17, 2015, DLC testing requirements may also include LM-84-14 if choosing Option 2 lumen maintenance determination. Below are the requirements as of July 17, 2015 for laboratories conducting LM-84-14 testing.

Test Laboratory Requirements As of July 17, 2015	
LM-84	<p>DLC will accept LM-84 results from laboratories that meet both of the following:</p> <ul style="list-style-type: none"> Listed in the DOE LED Lighting Facts® Approved Testing Laboratories List under LM-79 sections 9, 10, and 12* Accredited for LM-84-14 by an accreditation body recognized by LED Lighting Facts.* <p>Testing must be conducted within the accreditation effective and expiration dates detailed for a given laboratory. To find the LED Lighting Facts Approved Testing Laboratories List, visit:</p> <p>www.lightingfacts.com/approvedlabs</p>

Below are the Testing Laboratory Requirements that can be applied to test reports from laboratories with a test date prior to January 1, 2014.

Independent Testing Lab Requirements Applicable to testing conducted prior to January 1, 2014	
In-situ Temperature Measurement Test (ISTMT)	<p>Similar to ENERGY STAR requirements prior to September 30, 2010, the DLC will accept ISTMT results from laboratories:</p> <ul style="list-style-type: none"> • Approved by OSHA as Nationally Recognized Testing Laboratories (NRTLs). • Accredited by NVLAP for the LM-79-08 test procedure. • Recognized through UL’s Data Acceptance Program. (Referenced in the ENERGY STAR Manufacturer’s Guide, pg. 7)
LM-79	<p>Testing must be conducted at a laboratory listed in the LED Lighting Facts Approved Testing Laboratories List under LM-79 sections 9,10, and 12. Testing must be conducted within the laboratory’s accreditation effective and expiration dates.*</p>
LM-80	<p>The DLC will accept LED package in-house testing from the LED package/module/array manufacturer.</p>

XI. Application Process Overview

I. Prequalification Activities

To submit a product to be added to the QPL, please review this guide and the resources on the Solid State Lighting section of the [DLC website](#) to understand the DLC application process, including product performance requirements, supporting documentation requirements, and appropriate application fees. Below is an overview of the process:

Step 1: Create Manufacturer Login

On the DLC website select Sign In/Create an Account. Enter name, phone number, e-mail and create a personal password. If you plan to submit applications, select the checkbox and drop down will appear. Select your company from the list. If your company is not on the list, enter the company information. Select “Create Account.”

Step 2: Make sure your product is eligible.

Review the available Primary Uses and technical requirements. Your product must be marketed as and intended for a Primary Use to be eligible for qualification. Please review [Product Eligibility](#), the [Technical Requirements](#), and the [Testing and Reporting Requirements](#) for specific product categories to determine whether your product is eligible before submitting an application.

The application is evaluated against the requirements version in effect at the time the application is submitted. Resubmissions of an application are evaluated against either the original version technical requirements or the version in effect when the resubmission is received, at the discretion of the DLC reviewer.

Please note that the DLC reserves the right to alter or amend program policies, including technical requirements, and that such changes may result in products being removed from the QPL at the discretion of the DLC.

Step 3: Create Application





In the "My Applications" view click the green "Create Application" button. This will lead you to the "Create New Application" page. Enter the required "Application Details" and "Application Contact" information. Below is a description of each "Application Details" field:

- **Application Name:** Your reference name for the application. Please include a model number or series name of the products being submitted. You may include a DLC reviewer's name to request they review the application.
- **Application Description:** A space to provide any additional details you would like to provide the DLC reviewer regarding the application.
- **Application Type:** A drop-down menu of DLC application types. The selected type determines the required documentation needed in Step 4. Selecting an inappropriate application type will delay review times. See the [Submit a Product](#) page for more information about application types.

Step 4: Upload Documents

Creating the application will lead you to the "Application Home" page. On the left-hand side there is a menu of links. Click the "Documents" link. Within the documents section you can upload all supporting documentation. Each question requires a specific document. The supporting documentation varies by application type. Regardless of the Application Type, files must be individually uploaded in order to save progress. All "Required Documents" must be uploaded before you can submit an application. The "Optional Documents" are necessary for evaluating products against the Premium classification requirements and certain Primary Use designations. As shown below, there are five document icons that will help you to differentiate between required and optional documents, as well as uploaded documents. There are also options to delete or view/download a document after it has been uploaded.

Documents Icons

- Required document 
- Optional document 
- Uploaded document 
- Delete document 
- View/Download document 

Step 5: Read the Lab Testing Requirements page

This [web page](#) lists the testing laboratory requirements for the LM-79, ISTMT, and LM-80 (or LM-84) reports necessary for each application.

Step 6: Read the FAQ page

If you have additional questions after reviewing the Application Instructions, please read the [FAQ page](#). FAQs are updated regularly to reflect the most current DLC policies.

Step 7: Determine the appropriate application type: Single Product or Product Family Group

See [Application Types](#) for an explanation of each application type.

II. Submitting an Application

Step 8: Complete the Application by clicking the green "Submit Application" button in the top right-hand side of the "Documents" page. Please note that creating an application does not mean you have submitted an application. Per program guidelines, the Application Review Time Frames only apply after an application has been successfully submitted.

The application requirements have five main parts: application contact information, model information, photometric and electrical data, lumen maintenance, and document checklist. Each section must be completed and supported by the submission of documents listed: LM-79 test reports, LM-80 reports, ISTMT reports, and full IES files. See [application instructions](#) for information about the necessary documents and their validity requirements.

Step 9: Initial Application Review

After you submit an application a DLC reviewer will complete the Initial Review to determine if the application and supporting documentation are complete. At this stage in the process you will receive a message through the Application Portal to provide additional information to the DLC or to pay the appropriate application fees.

Condition 1: You are missing information, required information is insufficiently documented, there is an error in an independent lab test report, or the rated performance information shows the product does not meet the requirements. The reviewer will identify the specific areas in the application that need attention and allow you to fix problems and resubmit if appropriate. If additional application materials are required, you must provide the DLC reviewer with an estimate of when the additional information will be available and abide by the timeline established. Review of the application will commence when the additional materials are received and the application is considered complete.

Condition 2: You have submitted a complete application properly. You will receive an invoice for the applicable application fee. Once the invoice is paid, the Comprehensive Review phase begins. If the product meets the Technical Requirements, the DLC reviewer will let you know that the product qualifies and the product will be listed on the QPL. This application will then appear as complete in your account. If all documentation provided demonstrates the product does not meet the Technical Requirements, the product fails. The DLC reviewer will provide detailed information regarding which metrics did not meet the Technical Requirements. Any design changes made to the product after the initial review will require a new application and application fee.

The table below details Initial Review time frames. Please note that these time frames indicate the time to determine which condition above applies. Initial Reviews resulting in Condition 1 will delay the time before an invoice is sent.

Application Type	Initial Review
Single Product	2 Business Days
Family Grouping	5 Business Days
Private Label	5 Business Days
Product Update	5 Business Days

Step 10: Comprehensive Application Review

After application fee payment is received, your DLC reviewer will conduct a comprehensive review of all application materials and product performance data to determine whether your product(s) meet the Technical Requirements. After the Comprehensive Review is completed, you will receive a message through the Application Portal detailing which of the following conditions applies:

Condition 1: Your application is missing information, required information is insufficiently documented, or there is an error in an independent lab test. Your DLC reviewer will identify the specific areas in the application that need attention and allow you to fix problems and errors and resubmit if appropriate.

Condition 2: Performance information shows the product does not meet the Technical Requirements. An application showing product performance does not meet the category requirements may not be resubmitted; products must be redesigned, retested, and submitted as a new application with updated application materials and the appropriate application fee.

Condition 3: You have completed the application properly and the product meets all of the DLC requirements. You will receive notification of qualification when the product is listed on the QPL. This application will then appear as complete in your account.

The table below details Comprehensive Review time frames. Please note that these time frames indicate the time to determine which condition above applies. Comprehensive Reviews resulting in Condition 1 or Condition 2 will delay when the Comprehensive Review can be completed.

Application Type	Comprehensive Review
Single Product	10 Business Days
Family Grouping	10 Business Days
Private Label	5 Business Days
Product Update	10 Business Days

III. Application Types

1. Single Product Applications

The DLC defines Single Product applications as any ONE of the following:

Condition 1: Applications with one unique model number.

Condition 2: Applications with one base model number that includes variations that do not affect the performance of the product, such as:

- Dimming capabilities if the drivers used to achieve different dimming capabilities are the same aside from the dimming capability. In this instance "the same" means a driver from the same manufacturer in

the same product line. For example, Acme driver ABC-123-Fixed vs. Acme driver ABC-123-DIM

- Voltage variations if the drivers used to achieve different voltage ranges are the same aside from the voltage capability or if a stepdown transformer is used. In this instance "the same" means a driver from the same manufacturer in the same product line. For example, Acme driver ABC-123-120V vs. Acme driver ABC-123-480V. If a stepdown transformer is used, the same driver must be used with the stepdown transformer as is present in the model without the stepdown transformer.
- Miscellaneous variations that do not affect the performance, i.e. housing color, cord length, emergency battery pack, may be represented by placeholders (XX or **) or brackets
- Mounting options that **do not** affect the thermal environment or the intended application of the product may also be included.

Condition 3: Applications with multiple unique model numbers where the only variation among models is the Correlated Color Temperature (CCT) achieved by different phosphor coatings of the same series of LED package/model/arrays.

The submitted model number must indicate all variations present during the LM-79 and ISTMT testing. The DLC reviewer will work with manufacturers to utilize placeholders in the model number for options that do not affect the performance, when applicable. If products fall under the Single Product definition, please follow the [Single Product Application Instructions](#).

Under condition 3, LM-79 and ISTMT testing should be conducted on the worst case CCT variation (most likely the lowest CCT). In addition, an LM-79 report that contains [section 12 measurements](#) on the highest CCT must be provided.

Colorimetry data is required to verify that all additional CCT variations included in a Single Product Application meet the CCT requirement. If the manufacturer cannot provide the reviewer this information, the reviewer can qualify only the model number for which test data has been provided until test data is available for the additional CCT variations.

Products that use more than one CCT of a given LED are eligible. As with the general multiple-LED-types policy, LM-80 and ISTMT testing must be provided that covers both LEDs. If the LEDs are covered by the same LM-80, only the hottest LED overall will need to be tested. Please note, that DLC normally expects that, if other parameters are equal, lower CCT will be hotter than higher CCTs.

LEDs with more than one CCT that are dynamically controlled for purposes of color-tuning must meet the requirements of the Color Tuning Policy

2. Product Family Groups

Similar to other qualification programs, the DLC allows products that meet defined Product Family criteria to submit worst-case test data to qualify a group of products. The Product Family Grouping application process is intended to reduce testing costs by allowing manufacturers to determine the worst-case products within a group and demonstrate that the worst-case products meet the technical requirements. If the worst-case products meet the technical requirements, it can be assumed that all better-performing products within that group also meet them, and therefore additional testing on the better-performing products is not required. Product Family Groups must meet the conditions below to be eligible.

Please review the following before applying:

- [The DLC QPL categories and requirements](#)
- [The Independent Testing Lab Requirements](#)
- ["What is Worst Case" presentation \(pdf\)](#)

Family Grouping Applications should only be used for family groups that meet the following definition:

Condition 1a: Meet the Product Family Definition

- a) A family must contain a single LED package/module/array, or standardized set of LED packages/modules/arrays (see [Multiple LEDs policy](#))
- b) A family may contain multiple driver variations as well as different LED drive currents achieved by an adjustable driver.
 - a. If multiple driver variations are included within the family group, please refer to the [Testing Requirements](#) for specific instructions.
- c) The overall physical fixture housing and assembly must meet both of the following requirements:
 - a. Of identical material, construction, and shape, differing only in overall physical dimension for different models within the product grouping (see Subgroup definition). If the family group differs in overall dimension for different models within the group, each dimensional change will be grouped in a Sub-group.
 - b. In all other ways, thermally relatable to other fixtures in the family. That is, products can reliably be identified as to which are operating hotter or cooler.
- d) The fixture must demonstrate scalability or modular use of the identical LED packages/modules/arrays employed in the product.
- e) Other design parameters and components, such as electronics, optics, heat sinking, and other performance-affecting and non-performance affecting features are typically allowed to vary, consistent with this policy and provided that impact on

performance is well-understood and explained by the manufacturer applicant. DLC reserves the right to request additional information confirming that these features do not affect performance.

- f) A family may contain variations in fixture mounting systems if mounting systems do not change thermal management characteristics

Condition 2: Comply with Product Family Group Testing Concepts

The DLC’s intention is to assure quality and lifetime performance of all family members through testing and documentation rigorous enough to offer confidence in the affected products. Accordingly, Product Family Groups must provide worst-case testing for light output (LM-79), efficacy (LM-79), and lumen maintenance (ISTMT/LM-80/TM-21). IES files for each optical variation and worst-case power factor and THD measurements are also required, though this information may be represented by other worst-case test reports.

Independent Test Reports Required for Each Family Group

Criterion	Test Required
Minimum Light Output	LM-79
Allowable CCT	LM-79
Minimum CRI	LM-79
Power Quality (THDi and Power Factor)	LM-79

Each of the required LM-79 reports for “worst case” performance must include the necessary information for DLC to verify that the parameter in question meets the DLC requirements. For example, the “lowest light output” LM-79 test report must include light output measurements.

Currently, DLC only requires a sample size of one sample of a product to be tested for each required LM-79. Please note that testing conducted and submitted is assumed to be representative of the model number generally. If data shows that the product does not meet the Technical Requirements in effect at the time of submission, DLC will not qualify the product.

If both integrating sphere and goniophotometer measurements are submitted, the DLC will evaluate the lower performing values between the two measurement methods. Both measurement methods are acceptable methods for measuring the photometric performance of a product as defined by IES LM-79-08 Approved Method: Electrical and Photometric Measurements of Solid-State Lighting Products. Additionally, the DLC requires that products meet the Technical Requirements regardless of the approved method used to

measure performance. In the event that the measurements conducted by one method do not meet the requirements, the DLC will not ignore those measurements and evaluate the better performing measurements conducted by the other method.

Independent Test Reports Required for Each Family Group or Sub-group of a Family Group

Criterion	Test Required
Minimum Luminaire Efficacy	LM-79
Minimum L70 Lifetime	ISTMT
	LM-80 for single LED package as required for Lumen Maintenance projection through Option 1
Driver Reliability (applicable to products seeking DLC Premium Classification only)	Driver ISTMT

In House Test Reports Allowed: Test Reports Required for Each Family Group

Criterion	Test Required
<p>Zonal Lumen Density (IES files)</p>	<p>LM-79</p> <p>IES file for each unique optical and distribution pattern is required.</p> <p>This requirement applies to any variation in the product design that would impact the overall distribution of the product, including but not limited to: TIR optics, lenses, reflectors, refractors, and products of different geometries (i.e. screw-base replacements of different lengths)</p>
<p>Driver Characteristics</p>	<p>Driver output electrical measurements</p>

Condition 3: Provide Accurate Scaled Performance Information for All Models within the Group.

The manufacturer is responsible for designating the worst-case models in a group. The DLC requires that manufacturers provide scaled performance information for each product within a group to ensure the manufacturer has correctly designated the worst-case models. Acceptable sources for scaled performance information are:

- a) In-house laboratory test: In-house test reports from tests conducted in accordance with LM-79
- b) Calculated scaling: Mathematical characterization of luminaire performance based on manufacturer-developed scaling methodology. The manufacturer must provide a description of the scaling methodology and the technical basis for its validity. The DLC reserves the right to accept or reject the methodology for use in qualifying products.

If products fall under the Product Family definition, please follow the [Product Family Group Application Instructions](#).

Product Family Grouping Testing Guidance

The following testing guidance represents typical expectations of worst case performance variations within a family group. Manufacturers are responsible for demonstrating that products identified and tested as worst case performance do in fact represent the worst case, regardless of whether these typical expectations hold true for the submitted family group. Determination of worst case performance variations will be evaluated through the scaled performance information and the scaling methodology explanation.

Minimum Light Output

- The product that is expected to have the lowest overall light output (or lumens-per-foot, as applicable) must be tested according to LM-79. In general, this is expected to be the product with the fewest number of LEDs, lowest drive current, least efficient optic, and lowest CCT within the family group.
- Please note that if your family group application seeks qualification for your products in more than one Primary Use designation, testing must demonstrate compliance with the requirements for each Primary Use. This may result in the need to provide additional "worst-case light-output" LM-79s, or for a single test to be evaluated more than one time.
 - The only exception to the above will be for groups that cross light output bins in outdoor categories: while these groups must supply worst-case light output testing for the whole group, determination of the appropriate bin for family members will be made on the basis of the scaled performance table. Please note that testing must still demonstrate compliance with all efficacy levels, as noted below in the [efficacy testing section](#).

Allowable CCT

- Testing must be provided on a product that is at the representative highest CCT within the family group. For example, if the group includes products at 3000, 4000, and 5000K, at least one product at 5000K must be tested.

- Please note, because DLC requirements have lower- and upper-bounds on CCT, color data will be needed at both the lowest and highest CCTs. However, since the worst-case efficacy and worst-case light output products are expected to be at the representative lowest CCT, it is expected that tests for those parameters will cover this need.
- The LM-79 test report provided to satisfy this requirement must at least contain section 12 color measurements for a representative model at the highest CCT within the family group.

Minimum CRI

- Testing must be provided on the product that is expected to have lowest representative CRI within the family group. For example, the group includes 80 CRI and 90 CRI variations, testing must be conducted on at least one 80 CRI variant.
- The LM-79 test report provided must at least contain section 12 color measurements for the model that represents the lowest CRI option.
- Note that CRI variations are expected to affect light output, efficacy, and thermals. CRI variations should be considered when determining overall worst case light output, efficacy, and thermal models within the family group.

Power Quality

- Electrical testing must be provided for the product that is expected to have the worst-case THD and PF in the group. In general, this is expected to be on the product with the driver with the least optimal loading condition. In situations where there is more than one driver in the group, in-house testing will be needed to demonstrate that the worst-case driver, loading condition, and input voltage have been selected for testing.
 - Power factor and THD graphs that compare the loading of the driver to the power quality performance must be provided for each driver of the family group, along with bench-top testing on the worst case loading for each driver used.
- In-house testing is allowed for power quality metrics.
- Due to design complexities of SSL luminaires and the many variables that could affect each performance metric with a minimum requirement, it is difficult to prescribe what worst case will be for all situations. It is the manufacturer's responsibility to identify the worst-case operating mode of the product for each performance metric requirement and provide the appropriate test data. The DLC always reserves the right to ask for details of how worst-case was determined, including supporting engineering analysis and test data supporting the selection, as deemed necessary.
- Our understanding of the technology has led us to expect certain operating modes and design choices to be the worst cases. Power factor and THD are commonly seen to be worst case at 277V, while photometrics

(specifically efficacy) are commonly worst case at 120V. This is not necessarily true for all luminaire designs, so a manufacturer may submit independent test data for a different operating mode if it is accompanied by a technical rationale and supporting data (independent or in-house) demonstrating that what was tested is in fact the worst case. If testing is not conducted according to the expectations described above, DLC reviewers will ask for the testing at the expected worst case operating modes, or a technical rationale with supporting data for an alternate worst case operating mode for both electricals (power factor and THD) and photometrics.

- Alternately, if the voltage inputs for a product include 347V and/or 480V options, manufacturers will be expected to provide a rationale for how worst-case was determined, or test data at all voltages if a rationale cannot be provided for a particular operating mode.
- When submitting applications for products using universal drivers, be sure to test at the appropriate operating mode for both photometric and electrical measurements. Please note that the DLC requires the current THD ("THDi" or "ATHD") performance, not voltage THD.

Minimum Luminaire Efficacy

- Testing must be provided for each product expected to have the lowest lumens/Watt in each sub-group of the family. When determining worst-case efficacy, manufacturers must demonstrate that they are factoring in all variations that will affect this metric, including light output (LED counts and drive current), CCT, optical efficiencies, driver and applicable operating conditions, and thermal affects.
- Note that there are many factors that can influence efficacy. Manufacturers shall determine and justify the combination of factors that result in the worst case efficacy of each sub-group. DLC always reserves the right to ask for additional information to clarify or verify technical justification.
- If the family contains multiple drivers, driver spec sheets with efficiency curves must be provided, as well as bench-top testing demonstrating the driver efficiency at the applicable loading conditions and at the applicable input voltages.
- Please note that if your family grouping crosses requirement variables that have different efficacy requirements -- for example, across classifications or across light output bins for outdoor products -- testing must demonstrate that the products in the group meet all applicable requirements. This may result in the need to provide additional "worst-case efficacy" LM-79s.

Minimum L70 Determination

- The product with the worst-case lumen maintenance must demonstrate that it meets the DLC lumen maintenance requirements. Critically, this is

normally expected to be on the product where the LED is operating at its highest temperature within the group. An ISTMT to support TM-21 projections must be conducted on the hottest LED in this (hottest) luminaire.

- This product is typically the model with the greatest number of LEDs, operated at the highest drive current, using the least efficient optics, and having the lowest CCT that results in the shortest life referenced as L70. If applying under Premium, the worst case thermal management model must also meet the L90 requirement.
- Worst case thermal measurements are required for each sub-group, as applicable.

Driver Spec Sheet and ISTMT Requirements (Premium Only)

- As part of the DLC Premium application process, manufacturers need to provide the following:
 - Test report from a lab that meets the DLC's Laboratory Requirements for ISTMTs. The report must include the measured temperature from the TMPps.
 - A picture of the TMPps location with an arrow indicating the thermocouple attachment point.
 - Documentation from the driver manufacturer that indicates the maximum case temperature for which the driver is designed to last $\geq 50,000$ hours, as well as the TMP location it designates for thermal testing.
 - Custom and integrated drivers must provide Documentation equivalent to that required for drivers from third-party vendors. Manufacturers must supply documentation indicating the maximum acceptable temperature for the driver for 50,000-hour life, as well as the TMP to be used during thermal testing and evaluation.
- The worst-case product within the group is expected to be the highest wattage model. The ISTMT report must be conducted at the applicable TMP location on the driver for the product where the driver operating temperature is worst-case.
- If multiple drivers exist within the family group, manufacturers are required to demonstrate which driver will result with the worst case with specific and relevant rationale. DLC reserves the right to ask for thermal test data on each unique driver if rationale is not specific enough to demonstrate worst case.
- The luminaire passes the driver ISTMT requirements if the measured temperature at the TMPps is less than or equal to the allowable operating temperature specified by the power supply manufacturer. Drivers shall be tested in-situ under steady-state operating conditions, with case temperature measured at the designated TMP.

- One or more additional thermocouples are attached to the power supply/driver at the TMPps. For off-the-shelf remote power supplies, manufacturers typically provide a measurement location (case temperature designated by a “dot” adjacent to a (tc) symbol) for warranty purposes. In situations where the TMPps is not designated by the manufacturer, or where power supplies are integrated with the LED package(s), array, or module(s), luminaire manufacturers should identify the TMPps to be used for warranty purposes. Note that this includes situations where the driver/power supply is not purchased from an outside vendor, and where the driver/power supply is integrated into the luminaire or lamp.
- The thermocouple tolerance shall conform to ASTM E230 Table 1 “Special Limits” ($\leq 1.1^{\circ}\text{C}$ or 0.4%, whichever is greater).
- Per the Premium Requirements, custom and integrated drivers must provide equivalent driver spec sheet documentation as drivers from third-party vendors. This also applies to private labeled drivers where the private labeler does not market the private labeled driver and therefore does not have a public-facing driver spec sheet for the driver. Equivalent driver spec sheet documentation must include information on the rated driver performance, including but not limited to: input and output characteristics, the maximum case temperature for which the driver is designed to last $\geq 50,000$ hours, TMP location, as well as the specific driver model number. Reviewers may ask for additional driver information.

Zonal Lumen Density

- The orientation used for testing should represent the orientation for which the product is intended. The test lab may redefine the orientation of the coordinate system if necessary.
- In house testing is allowed.
- IES file for each unique optical and distribution pattern is required
- Provide measurements from tests conducted in accordance with LM-79 (and reported as required for an LM-79 test) for a representative model for each different optical distribution offered in the family group.
 - This requirement applies to any variation in the product design that would impact the overall distribution of the product, including but not limited to: TIR optics, lenses, reflectors, refractors, and products of different geometries (i.e. screw-base replacements of different lengths)

The DLC calculates the zonal efficacy based on the lumen output in the 0-90° zone divided by the total wattage of the product. The lumen output in the 0-90° zone is calculated by taking the total lumen output of the product (based on the LM-79*), and calculating the lumen output in the 0-90° zone based on the percentage of lumens calculated in that zone from the accompanying IES file. Note that IES files are evaluated using Photometric Toolbox – Professional

Edition from Lighting Analysts, Inc. The lumen output calculated in the 0-90° zone is then divided by the total wattage to arrive at the zonal efficacy. This calculation is standardized across all application reviews. As such, the DLC cannot accept alternate values for zonal efficacy using a different calculation method.

Driver Characteristics

- For each unique driver used within a family group, manufacturers must provide electrical testing for each driver group to demonstrate which driver variation will result in the overall worst case metrics identified under the Independent Test Reports for Family Groups and Sub-groups.
 - In general, this testing should include the input voltage, current, and wattage, the output voltage, current, and wattage, and the THDi and PF, for each loading condition of each driver within the family group.
- In house testing is allowed.

3. Private Label Applications

The Private Labeling Policy is intended to allow manufacturers the option to re-list qualified products under multiple organizations and brands without having to submit duplicate testing information. Recognizing the varied needs of different types of organizations, the DLC requires the following supporting documentation to be submitted. This information should be sufficient for the large majority of private labeling partnerships and multiple listing scenarios. Organizations submitting information for multiple brands should provide this information and the applicable fees with the original application. Organizations submitting information to private label an original equipment manufacturer's (OEM) products must provide this documentation after the OEM products have been qualified.

Required Documentation

- Download and complete the [Private Label Application form \(xlsx\)](#). The OEM's qualified products must be downloaded directly from the DLC QPL and the model numbers listed in the form. Instructions for downloading products from the DLC QPL are available in the new How to Download the DLC QPL guidance.
 - Note: Private labels must include at least one OEM Parent model to be eligible. Please ensure the OEM products downloaded from the DLC QPL include at least one Parent model.
- Download and completed the [Private Label Agreement form \(docx\)](#). This is a statement briefly explaining the relationship between the two (or more) organizations or brands and certifying that the products to be listed are exactly the same in design and performance. This private label statement must be signed by representatives of all organizations involved. If one

organization is listing products under different brand names, the signature of a representative of the parent organization is sufficient.

- Note: An organization that is a signatory to the private label statement may choose to withdraw its consent at any time by submitting to the DLC a written request that the private label listing be terminated. Any such request must be signed by an authorized representative of the organization. Upon receipt of such request, the DLC will delist the private labeled model numbers from the QPL.
- A list of all model numbers submitted for qualification, showing the association of a base brand model number to the cross-listed model number(s).
- A product specification sheet for the new model numbers being submitted.
 - Manufacturer must submit the specification sheet they are using in the marketplace. Spec sheets created for DLC submission only are not acceptable.
 - Product specification sheet must clearly detail dimming capabilities if products capable of dimming are submitted.
- Safety Certification Documentation:
 - Compliance Certificate (OEM): All products are required to submit a compliance certificate from an approved safety certification organization relevant in the United States or Canada (see Testing Requirements below). This compliance document shall bear the Original Equipment Manufacturer's (OEM) name and will be proof that the products listed have been investigated by the safety organization and found to be in compliance with the standards listed on the certificate. The name of this document varies by safety organization; however, it is commonly referred to as a Certificate of Compliance or Authorization to Mark.
 - Compliance Certificate (Private Label): In addition to a compliance certificate from the OEM, the private labeler must also submit a compliance certificate from an approved safety certification organization which bears the private labeler's name and unique file number.
 - Private labelers that have multiple listed through Underwriters Laboratories Inc. (UL) will need to request the private labeler's compliance certificate from UL directly. This documentation is not provided automatically, but can be obtained from UL upon request.
 - Private labelers that have multiple listed through Intertek Testing Services NA, Inc. (ETL) will be required to provide the private labeler's compliance certificate if the multiple listing through ETL was processed on/after March 26, 2018. Multiple listings processed through ETL prior to March 26, 2018 will not be required to provide this documentation.
 - Multiple Listing Correlation Sheet: All products are required to submit a Multiple Listing correlation sheet issued by the approved safety organization which cross-references the OEM model numbers with private label model numbers.

- **Digital Signature:** During the application process, manufacturers will be required to digitally sign an agreement confirming that the safety documentation provided covers ALL models they wish to be listed on the QPL and that the products being sold will bear the proper markings from the safety organization.

Submitting a Private Label Application

To expedite payment, please have the manufacturer responsible for the application fees submit the required documentation.

XII. Application Fees

DLC requires manufacturers to submit an application fee to cover the costs of the review of their product applications. The specific amount of the fee is dependent upon the type of application submitted, and (in most cases) upon the details of the particular product group in the application submission. Credit card payments are preferred for fastest processing. Payment via check is also available, but typically takes longer. Instructions are available Invoice page when you are logged into your manufacturer account. Please note that if you pay by check, the DLC reviewer cannot process the application until all information has been provided and payment is received.

I. Single Product Applications

Single Product Applications are intended for application submissions where a manufacturer is seeking to qualify only a single product, or a small group of products with only limited variations. Under current DLC policies, only variations that do not affect performance — such as external housing color, CCT variations, voltage variations, or dimming capabilities are allowed within Single Product Applications.

The application fee for single product applications is \$500. Please note that Single Product Applications must have all relevant testing on the product specifically submitted in this application. Cross-applying of data from similar products is only allowed under family grouping applications.

Applications with special considerations, such as those submitting products for qualification in the DLC Premium classification, or in a Specialty Use designation, will include additional application fees noted in the relevant sections below.

The Single Product Application fee covers additional family members if the variations of those family members are limited to higher CCT, dimming variations, or variations that do not affect the performance of the product (mounting, housing color, etc).

II. Family Grouping Applications

Family Grouping Applications are intended for application submissions where a manufacturer is seeking to qualify a group of products with many variations in design and performance. Please refer to the Family Grouping page for details on what variations are allowable, and which are not.

Application fees for family groups are dependent upon the size and complexity of the group. In general, the fees schedule is as follows:

- \$500 per independent test report (ITR) evaluation required under the product group application procedure. Per the family grouping policy, the following report types are considered as ITRs:
 - LM-79s
 - LED ISTMTs
 - Driver ISTMTs (for Premium Classification)
- \$25 per additional product family member in the group. This is calculated as: Total Products in the Group – Number of ITR = Additional Family Members.
- \$400 for a family group submitted for qualification in the Specialty Use designation.
- For additional products necessary to be listed ONLY to identify the differing dimming performance (see [Dimming Policy](#)), manufacturers will either be required to pay the \$25 per product fee, or the fee based on the chart below, whichever amounts to the lower total application fee. Note that the size of the family group below is based on the total number of additional products necessary to be listed ONLY to identify the differing dimming performance.
- Family Grouping Application fees are dependent on the group of products submitted for qualification. Please see the [Application Fees](#) page for more details. A DLC reviewer will evaluate the product family, determine the fee, and confirm payment details with the manufacturer prior to invoicing

Number of Products in Family ONLY to Identify Differing Dimming Performance	Fee
1-10	\$260.00
11-100	\$365.00
101-500	\$445.00
501-1000	\$520.00
1001-2500	\$625.00
2501+	\$675.00

III. **Private Label Applications**

The Private Label Policy fees are based on those of the original application. The Private Labeling Application fees are as follows:

- \$250 for each \$500 charged through the original application
- \$25 per additional family member charged through the original application.
- For additional products necessary to be private labeled ONLY to identify the differing dimming performance (see [Dimming Policy](#)), manufacturers will either be required to pay the \$25 per product fee, or the fee based on the chart below, whichever amounts to the lower total application fee. Note that the size of the family group below is based on the total number of additional

products necessary to be listed ONLY to identify the differing dimming performance.

Number of Products in Family ONLY to Identify Differing Dimming Performance	Fee
1-10	\$260.00
11-100	\$365.00
101-500	\$445.00
501-1000	\$520.00
1001-2500	\$625.00
2501+	\$675.00

IV. DLC Premium Applications

Single Product or Family Grouping Applications containing products submitted under the Premium classification will include an application fee of \$500 for the evaluation of the Driver ISTMT.

V. Specialty Use Designation

Single Product or Family Grouping Applications containing products submitted under the Specialty Use designation will include an application fee of \$400 for the evaluation ensuring the products submitted meet the purpose of the DLC and the Specialty Use designation.

XIII. Application Instructions

I. General Application Instructions

1. Manufacturer Login

If you have not already done so, create a [Manufacturer Login](#). The DLC highly recommends that the application be filled out by a person with sufficient technical knowledge of lighting products and testing, such as a lighting engineer. Experience has shown that applications submitted by sales, marketing, or administrative staff often lack important details which delay overall processing.

To submit a product to be added to the QPL, please review this guide and the resources on the Solid State Lighting section of the DLC website to understand the DLC application process, including product performance requirements, supporting documentation requirements, and appropriate application fees.

2. Product Application Form

Download and complete the appropriate Product Application Form from the [Submit a Product](#) section of the website. See [Completing the Product Application Form](#) instructions below for more information.

3. Create Online Application

In the “My Applications” view please click the green “Create Application” button. This will lead you to the “Create New Application” page. Enter the required “Application Details” and “Application Contact” information. Below is a description of each field:

4. “Create New Application” Page

Fill in application information, including:

Application Details

- Application Name: Your reference name for the application. Please include a model number or series name of the products being submitted. You may include a DLC reviewer’s name to request they review the application.
- Application Description: A space to provide any additional details you would like to provide the DLC reviewer regarding the application.
- Application Type: A drop-down menu of DLC application types. The selected type determines the required documentation.





Application Contact

- Contact Name: This field is auto-populated from your user account information. It may be edited for the submitted application.
- Contact Email Address: This field is auto-populated from your user account information. It may be edited for the submitted application.
- Contact Phone Number: This field is auto-populated from your user account information. It may be edited for the submitted application.

5. Upload Required Documentation

Creating the application will lead you to the “Application Home” page. On the left-hand side there is a menu of links. Please click the “Documents” link. Within the Documents section you can upload all supporting documentation. Each question requires a specific document. The supporting documentation varies by application type. Files must be individually uploaded in order to save progress. Furthermore, all “Required Documents” must be uploaded before you can submit the application. The “Optional Documents” are necessary for evaluating products against the Premium classification requirements and certain Primary Use designations. As shown below, there are five document icons that will help you to differentiate between required and optional documents as well as uploaded documents. There are also options to delete or view/ download a document.

Documents Icons

• Required document		• Delete document	
• Optional document		• View/Download document	
• Uploaded document			

a) **Completed Product Application Form**

The Product Application Form includes a sample of a completed form, which can be found on the second tab of the document.

b) **Manufacturer Product Specification Sheet**

The manufacturer product specification sheet is the marketing document the manufacturer supplies to customers interested in purchasing the product. Product specification sheets often include images of the product, intended application(s), ordering codes and available variations, and rated performance. Product specification sheets may also be referred to as cut sheets, sell sheets, product brochures, or catalogs. Product specification sheet must clearly detail dimming capabilities if the products are capable of dimming.

c) **LED Package Specification Sheet**

The LED package specification sheet is the marketing document the LED package/module/array manufacturer supplies to customers interested in purchasing the product. The LED package specification sheet often includes images of the product, ordering codes, schematic diagrams, and rated performance. The LED package specification sheet can be obtained from the LED package/module/array manufacturer.

d) **LM-79 Report(s) Containing Sections 9, 10, and 12**
Sections 9, 10, and 12 may be combined in the same PDF report or provided separately. Unique, relevant part numbers matching the submitted model number in the Application Form must be listed on each report. Supplemental power quality test report or LM-79 with worst case power factor and total harmonic distortion (THD) measurements, if not included in primary LM-79.

e) **IES Photometric File**

The IES file has the file extension “.ies”. The IES file must include a unique, relevant part number, test lab name, and test date. IES files are evaluated for zonal lumen density and/or spacing criteria compliance using Photometric Toolbox – Professional Edition from Lighting Analysts, Inc. IES files must show the product oriented as it would be mounted in the field, with the exception of products in the Landscape Flood and Spot Luminaires and Architectural Flood and Spot Luminaires primary use designations (PUDs). For products seeking qualification in these PUDs, IES files must be oriented with the center of the beam at 0,0 angle.

f) **Warranty Document**

The warranty document is the legal warranty document explaining all warranty terms and conditions associated with the submitted product(s). The DLC requires a minimum warranty period of 5 years on all products listed on the QPL. The warranty must cover the complete luminaire, or retrofit kit/replacement lamp when applicable.

Note that the “luminaire” includes light source, housing, heat sink, power supplies and other electrical components, optics, and any other components of the luminaire. Warranty documentation must clearly explain the terms and conditions associated with the warranty.

Warranties that only cover certain components of the luminaire or retrofit kit/replacement lamp are not sufficient to meet the requirement. Warranty statements are reviewed on a case-by-case basis and the DLC reserves the right to seek additional clarification if necessary.

Warranty terms and conditions can vary widely from manufacturer to manufacturer. The DLC explicitly defines a warranty period of 5 years and does not have specific requirements for warranty claim terms other than those listed above. The DLC does not verify or validate a manufacturer’s terms, conditions or process for customer warranty claims. The DLC does not monitor field failure rates of qualified products, or policy warranty redemption or history among

manufacturers. Industry stakeholders are urged to review warranty terms and conditions as part of the purchasing decision process.

g) Product Installation Instructions (for retrofit kits and replacement lamps only)

Product installation instructions are required only for retrofit kits and linear replacement lamp applications (categories 21 through 32). Installation instructions must detail all necessary steps for installing the retrofit kit or replacement lamp. They should be the same instructions provided to the end-user.

h) Proof of Safety Certification

• **Compliance Certificate**

All products are required to submit a compliance certificate from an approved safety certification organization relevant in the United States or Canada. This compliance document shall bear the manufacturer's name and will be proof that the products listed have been investigated by the safety organization and found to be in compliance with the standards listed on the certificate. The name of this document varies by safety organization; however, it is commonly referred to as a Certificate of Compliance or Authorization to Mark.

• **Digital Signature**

During the application process, manufacturers will be required to digitally sign an agreement confirming that the safety documentation they are providing with the application covers ALL models they wish to be listed on the QPL and that the products being sold will bear the proper markings from the safety organization.

- **Note:** If, after qualification, the safety documentation gets updated so that any model number(s) listed on the QPL are no longer covered by the original safety certificate, it is the responsibility of the manufacturer to submit the revised documentation to the DLC so that the DLC records can be updated accordingly. Failure to do so may result in the product and any associated family members or private labels of the product being delisted.

i) Lumen Maintenance Information:

Lumen maintenance information is required for each worst case thermal family member: select one of the two options and submit all of the corresponding required documentation. For more information regarding lumen maintenance, please see the [Technical Requirements Table](#).

(1) Option 1: Component Performance

- IES LM-80-15 test report
 - Note: Manufacturers are expected to provide the most recent LM-80 report available for the

LED package/module/array used in the product

- Schematic/photograph from LED package/module/array manufacturer that shows the specified temperature measurement point (TMP)

See [Understanding Testing Principles: Lumen Maintenance](#) and [Completing the Single Product Application Form](#) for details.

- In-situ temperature measurement test (ISTMT) report
 - Photograph of temperature measurement (i.e., attached thermocouple) showing that the temperature is measured at the TMP specified by the LED package/module/array manufacturer

See [Understanding Testing Principles: ISTMT](#) and [Completing the Single Product Application Form](#) for details.

- Saved copy of the completed ENERGY STAR TM-21 calculator worksheet (Microsoft Excel file format), available for download at https://www.energystar.gov/sites/default/files/ENERGY%20STAR%20TM-21%20Calculator%20rev%2002-08-2016%20clean_0.xlsx.

(2) Option 2: Luminaire Performance

- LM-84-14 test report
- Saved copy of the completed ENERGY STAR TM-28 worksheet (Excel file format), [available for download here](#).
- LM-80-08 test report for the LED package/module/array if using Combined Extrapolation approach per TM-28
 - Note: Manufacturers are expected to provide the most recent LM-80 report available for the LED package/module/array used in the product
- ENERGY STAR TM-21 worksheet (Excel file format) if using Combined Extrapolation approach per TM-28

6. Digitally sign the Application Agreement and submit the Application

Complete the Application by clicking the green “Submit Application” button in the top right-hand side of the “Documents” page. This button will present you with a digital Application Agreement that includes the DLC Self-Certification Statement, Logo Guidelines Compliance Statement, Surveillance Testing Compliance Statement, and Safety Certification Compliance Statement. [Full text of the agreement is available here.](#) Sign the agreement to submit your application.

Please note that creating an application does not mean you have submitted an application. Per program guidelines, the Application Review Time Frames only apply after an application has been successfully submitted. The application requirements have five main parts: application contact information, model information, photometric and electrical data, lumen maintenance, and document checklist. Each section must be completed and supported by the submission of documents listed: LM-79 test reports, LM-80 reports, ISTMT reports, and full IES files.

7. Initial Application Review

After you submit an application a DLC reviewer will complete the Initial Review to determine if the application and supporting documentation are complete. At this stage in the process you will receive a message through the Application Management System to provide additional information to the DLC or to pay the appropriate application fees.

Condition 1: You are missing information, required information is insufficiently documented, there is an error in an independent lab test report, or the performance information shows the product does not meet the requirements. The reviewer will identify the specific areas in the application that need attention and allow you to fix problems and resubmit if appropriate. An application showing product performance does not meet the Primary Use requirements may not be resubmitted; products must be redesigned, retested, and submitted as a new application with updated application materials.

Condition 2: You have submitted a complete application properly. You will receive an invoice for the applicable application fee. Once the invoice is paid, the Comprehensive Review phase begins. Upon completion of the Comprehensive Review you will receive notification of qualification when the product is listed on the QPL. This application will then appear as complete in your account.

The table below details Initial Review time frames. Please note that these time frames indicate the time to determine which condition above applies. Initial Reviews resulting in Condition 1 will delay the time before an invoice is sent.

Application Type	Initial Review
Single Product	2 Business Days
Family Grouping	5 Business Days
Private Label	5 Business Days
Product Update	5 Business Days

8. Comprehensive Application Review

After application fee payment is received, your DLC reviewer will conduct a comprehensive review of all application materials and product performance data to determine if your product(s) meet the Technical Requirements. After the Comprehensive Review is completed, you will receive a message through the Application Portal detailing which of the following conditions applies:

Condition 1: Your application is missing information, required information is insufficiently documented, or there is an error in an independent lab test. Your DLC reviewer will identify the specific areas in the application that need attention and allow you to fix problems and errors and resubmit if appropriate.

Condition 2: Performance information shows the product does not meet the Technical Requirements. An application showing product performance does not meet the category requirements may not be resubmitted; products must be redesigned, retested, and submitted as a new application with updated application materials and the appropriate application fee.

Condition 3: You have completed the application properly and the product meets all of the DLC requirements. You will receive notification of qualification when the product is listed on the QPL. This application will then appear as complete in your account.

The table below details Comprehensive Review time frames. Please note that these time frames indicate the time to determine which condition above applies. Comprehensive Reviews resulting in Condition 1 or Condition 2 will delay when the Comprehensive Review can be completed.

Application Type	Comprehensive Review
Single Product	10 Business Days
Family Grouping	10 Business Days
Private Label	5 Business Days
Product Update	10 Business Days

Notes about Application Materials:

*All supporting documentation must include the specific, relevant model or part number.

Documents and files related to the luminaire (e.g., LM-79-08, ISTMT) must include the unique model number of the luminaire that is named on the application. Documentation related to the LED package/module/array (e.g., the LM-80 report) must include the part number of the specific LED package/module/array that is named in the application. Please see the FAQs page for further clarification regarding these individual test reports. Please communicate with any independent laboratory the exact luminaire model number that it should include in its test reports.

*If the submitting organization's name is not represented within the test reports provided with the application, please submit the [Test Report Authorization form \(docx\)](#).

***Our file naming conventions:**

When uploading documentation to the application, please include the report type in the file name (i.e., "filenameABC_LM-79" or "filenameABC_product_spec_sheet."). Naming the files appropriately in the application will speed up review time. The system will allow you to replace and delete files as necessary before submitting.

***Acceptable sources for self-reported/rated performance data:**

1. In-house laboratory test — In-house test reports from tests conducted in accordance with IESNA LM-79
2. Calculated Scaling — Provide mathematical characterization of luminaire performance based on manufacturer-developed scaling methodology. The manufacturer must provide a description of the scaling methodology employed and the technical basis for its validity. The DLC reserves the right to accept or reject the methodology for use in qualifying products.

Application Fees:

DLC requires a processing fee to accompany an application submittal. Application fees for Family Group applications are primarily determined by the number of test reports needed to appropriately bracket the group and the number of additional family members. For more information on the details of the application fee structure, please refer to the [Application Fees](#) page.

II. **Single Product Application Instructions**

The following information describes the process of completing the Product Application Form for products that meet the [Single Product definition](#).

Completing the Product Application Form

1. Tab 1: "Application Form"

- a) **Section 1: Company and Application Contact Information**
- *Company*: Enter the name of your organization. Please note that this organization name will appear on the QPL.
 - *Brand*: Enter the name of the brand your product is sold under. Please note that this brand name will appear on the QPL.
 - *Contact Name, Phone, Email*: Enter the name of and contact information for the person within your organization that questions regarding this application submission should be directed to.
 - *Website*: Please enter the website for your company. If the product is listed on a different webpage, please enter that as well.
- b) **Section 2: Application Type**
- Please select the application type that corresponds with the application you are submitting. For single product applications, this will be "Single Product Application".
- c) **Section 3: Primary Use Information**
- Please select the appropriate information for the application you are making in each cell. The categories correspond with structure of the Technical Requirements Table. If you are unsure which category your product falls into, please see the guidelines on [product eligibility](#).
 - If you are submitting the product as a "Specialty Use" product within a general application, please provide a short description of the types of applications the product is intended to be used for. Supplemental images provided with the application are often helpful to the DLC review staff in evaluating applications efficiently.
 - *DLC Category*: Select the primary use you are submitting these products for consideration under. Please refer to the Technical Requirements Table if you are unsure.
 - *General Application*: Select the General Application you are submitting these products for consideration under. Please refer to the Technical Requirements Table if you are unsure.
 - *Primary Use*: Select the Primary Use designation are submitting these products for consideration under. Please refer to the Technical Requirements Table if you are unsure.
 - *Specialty Use Description*: If you are submitting the product as a "Specialty Use" product within a general application, please provide a short description of the types of

applications the product is intended to be used for. Supplemental images provided with the application are often helpful to the DLC review staff in evaluating applications efficiently.

- *DLC Classification*: Please indicate the classification you are submitting each product for consideration under in the Scaled Performance Table tab. This should be "Standard" or "Premium".

d) **Section 4: Product Information**

- Please provide the requested information regarding the design and testing of your product.
- *Rated Voltage*: Enter the voltage range you market your product to operate on. E.g. 120-277V.
- *Driver Model Number*: Enter the model number for the driver you are using in your product. Please note that spec sheets must be included for DLC Premium applications, but are encouraged to be provided in all cases.
- *LED Package/Module/Array Part Number*: Enter the part number for the LED package/module/array you are using in your product. Please keep in mind that the DLC follows the [ENERGY STAR guidance](#) on LM-80 testing and evaluation.
- *LED Drive Current*: Enter the current at which you are driving your LEDs. If you are using a Chip-on-Board package/array in your product, please include both the drive current for the array and the calculated current-per-die.
- *Accessories*: If any additional accessories are employed in the testing of your product, please note those details in this field. Note that retrofit kits must be tested in a reference housing; the model number for that housing must be listed in this field.
- *Description*: Please enter a detailed description of your product or product group.
- *Controls*: Please indicate whether customers can order your product with integral sensors for occupancy sensing and photo control. DLC reviewers will verify these claims against information found in your spec sheet. This information is required for products seeking qualification in the DLC Premium classification, and optional for those in seeking qualification in the DLC Standard classification.
- *Dimmability*: Please indicate whether or not this application includes products that are dimmable. Be sure to indicate the dimming performance of each product on the Scaled Performance Table tab.

Please note that any section grayed-out, such as the section on housing variations, does not need to be completed for single-product applications. These sections are only applicable to Family Grouping applications.

- e) **Section 5: Product Identifier Information**
- *Ordering Code/Model Number Information:* Enter a description of the character codes that make up your model number/ordering code. This description should be detailed enough for your DLC reviewer to understand what each character in your model number represents, and should be consistent with the information supplied in your spec sheet.

2. **Tab 2: "Scaled Performance Table"**

- a) **Section 1: Scaling Methodology**
- Please explain the methodology used in developing the rated performance information for the products in this submission. This explanation should be sufficiently detailed to cover all variations within the product group, and for the DLC reviewer to be able to follow the engineering logic and development of any value in the table. Manufacturers may provide additional information on their scaling methodology in separate documents as necessary to communicate these details.
- b) **Section 2: Performance Table**
- Please provide the information requested in each column for every product in the group you are submitting for application. Please include only those products you are submitting for application.
 - *Primary/Specialty Use:* Please enter the Primary Use designation you are submitting these products for qualification under, consistent with the DLC Technical Requirements table. If you are submitting these products under the "Specialty" designation, please include "Specialty:" along with the name of the end-use application these products will be used in in the market place. For example, stadium lighting would be "Specialty: Stadium Lighting."
 - *Classification:* Please enter the DLC classification you are seeking qualification for each product in: Premium or Standard. The requirements for each classification can be found on the Technical Requirements page.
 - *System Type:* Please enter whether the product operates on an AC system or a DC or PoE system.

- *Minimum and Maximum Input Voltage*: Enter the voltage range for the product in these columns.
- *Model Number*: Please enter the complete model numbers for the products you are seeking qualification for in this column. Please note that model numbers must be complete model numbers, including all details to specify the performance of the product. Wild-card characters may only be used to represent variations that do not affect performance, such as exterior housing color.
- *Scaled Initial Light Output*: Please enter the expected light output for the products in your group in this column. Rated data must be representative of the tested configuration of the products within the application. For Linear Replacement Lamps and Four Pin-Base Replacements for CFLs, the rated data must be representative of the bare lamp, including any ballast losses for Type A lamps. For Retrofit Kits and Mogul Screw-Base Replacements for HID Lamps, the rated data must be representative of the product tested in the appropriate reference housing. Please be sure that these values are traceable to the scaling methodology you describe.
- *Scaled Luminaire Efficacy (AC)*: Please enter the expected efficacy for the AC products in your group in this column. If the product is a DC/PoE product, leave this field blank. Rated data must be representative of the tested configuration of the products within the application. For Linear Replacement Lamps and Four Pin-Base Replacements for CFLs, the rated data must be representative of the bare lamp, including any ballast losses for Type A lamps. For Retrofit Kits and Mogul Screw-Base Replacements for HID Lamps, the rated data must be representative of the product tested in the appropriate reference housing. Please be sure that these values are traceable to the scaling methodology you describe.
- *Scaled Efficacy (DC)*: Please enter the expected efficacy for the DC products in your group in this column. If the product is an AC product, leave this field blank.
- *Scaled Input Power*: Please enter the expected power (wattage) for the products in your group in this column. Rated data must be representative of the tested configuration of the products within the application. For Linear Replacement Lamps and Four Pin-Base Replacements for CFLs, the rated data must be representative of the bare lamp, including any ballast losses for Type A lamps. For Retrofit Kits and Mogul Screw-Base Replacements for HID

Lamps, the rated data must be representative of the product tested in the appropriate reference housing. Please be sure that these values are traceable to the scaling methodology you describe.

- *Scaled Total Harmonic Distortion*: Please enter the expected THD for the products in your group in this column. Rated data must be representative of the tested configuration of the products within the application. For Linear Replacement Lamps and Four Pin-Base Replacements for CFLs, the rated data must be representative of the bare lamp, including any ballast losses for Type A lamps. For Retrofit Kits and Mogul Screw-Base Replacements for HID Lamps, the rated data must be representative of the product tested in the appropriate reference housing. Please be sure that these values are traceable to the scaling methodology you describe.
- *Scaled Power Factor*: Please enter the expected power factor for the products in your group in this column. Rated data must be representative of the tested configuration of the products within the application. For Linear Replacement Lamps and Four Pin-Base Replacements for CFLs, the rated data must be representative of the bare lamp, including any ballast losses for Type A lamps. For Retrofit Kits and Mogul Screw-Base Replacements for HID Lamps, the rated data must be representative of the product tested in the appropriate reference housing. Please be sure that these values are traceable to the scaling methodology you describe.
- *Scaled CCT*: Please enter the expected correlated color temperature (CCT) for the products in your group in this column. Rated data must be representative of the tested configuration of the products within the application. For Linear Replacement Lamps and Four Pin-Base Replacements for CFLs, the rated data must be representative of the bare lamp, including any ballast losses for Type A lamps. For Retrofit Kits and Mogul Screw-Base Replacements for HID Lamps, the rated data must be representative of the product tested in the appropriate reference housing. Please be sure that these values are traceable to the scaling methodology you describe.
- *Scaled CRI*: Please enter the expected color rendering index (CRI) for the products in your group in this column. Rated data must be representative of the tested configuration of the products within the application. For Linear Replacement Lamps and Four Pin-Base Replacements for CFLs, the rated

data must be representative of the bare lamp, including any ballast losses for Type A lamps. For Retrofit Kits and Mogul Screw-Base Replacements for HID Lamps, the rated data must be representative of the product tested in the appropriate reference housing. Please be sure that these values are traceable to the scaling methodology you describe.

- *Housing Variation*: This field is not needed for single product applications. If your product group includes housing variations, please see the Family Grouping rules.
- *Driver Model Number*: Please enter the driver model number(s) for the driver(s) used by each product in the application.
- *Vertical NEMA Beam Spread*: If you are seeking qualification for your product in one of the flood or spot Primary Use designations, please enter vertical NEMA Beam classification.
- *Horizontal NEMA Beam Spread*: If you are seeking qualification for your product in one of the flood or spot Primary Use designations, please enter horizontal NEMA Beam classification.
- *Base Type*: Enter the base type if the product is a linear replacement lamp or mogul-screw base product.
- *Sensors*: Please indicate whether your products can be ordered with integral occupancy sensors or photocontrols. This field must be filled out for products seeking qualification in the DLC Premium classification, and is optional for products in the DLC Standard classification.
- *Dimming Capability*: Please indicate whether your product is dimmable. If the product is dimmable, fill out the dimming type, minimum dimming level, default light output, and default wattage in the columns that follow.
- *Dimming Type*: If your product is dimmable, please indicate whether it dims in a continuous or stepped manner.
- *Minimum Dimming Level*: If your product dims continuously, please indicate whether it can dim to $\leq 10\%$ of its full input power. Please note this question is about the power consumed by the product in the dimmed state, not the light output.
- *Field Adjustable Light Output*: Mark whether the product is capable of adjusting the light output in the field. If the product is field adjustable, enter the default light output, default wattage, minimum wattage, minimum light output, and maximum light output in the subsequent columns.

- *Length*: If you are seeking qualification for your product in one of the screw-base replacements for HID lamps, linear ambient, or display case luminaires Primary Use designation, please enter the length of the product in inches.
- *Rf*: If you wish to provide information about the product's Fidelity Index (Rf) according to TM-30, please indicate the value here. This metric is currently optional, and not required for listing. To list this metric for products on the QPL, you must use the official Excel version of the TM-30 calculation tool offered with the IES standard.
- *Rg*: If you wish to provide information about the product's Gamut Index (Rg) according to TM-30, please indicate the value here. This metric is currently optional, and not required for listing. To list this metric for products on the QPL, you must use the official Excel version of the TM-30 calculation tool offered with the IES standard.
- *Safety Organization and File Number*: Please enter the organization under which the products are safety certified and the file number for the certification document
- *White Tunable*: Mark whether the product is white tunable. If the product is white tunable, enter the minimum CCT, maximum CCT, maximum wattage, and minimum wattage in the subsequent columns.
- *Dim-to-Warm*: Enter Yes or No to specify whether the product can dim-to-warm.

III. **Family Grouping Application Instructions**

The following information describes the process of completing the manufacturer electronic application form for products that meet the [Product Family definition](#). The application form is split into several sections to simplify both application and review. Please refer to the instructions below for any questions regarding how to appropriately use this form for Family Grouping submissions:

Completing the Product Application Form

1. Tab 1: "Application Form"

- a) **Section 1: Company and Application Contact Information**
- Please fill out the requested information, as detailed below.
 - *Company*: Enter the name of your organization. Please note that this organization name will appear on the QPL.
 - *Brand*: Enter the name of the brand your product is sold under. Please note that this brand name will appear on the QPL.
 - *Contact Name, Phone, Email*: Enter the name of and contact information for the person within your organization that questions regarding this application submission should be directed to.

- *Website*: Please enter the website for your company. If the product is listed on a different webpage, please enter that as well.
- b) **Section 2: Application Type**
- Please select the application type that corresponds with the application you are submitting. For Family Grouping applications, this will be "Family Grouping Application".
- c) **Section 3: Primary Use Information**
- Please select the appropriate information for the application you are making in each cell. The categories correspond with structure of the [Technical Requirements Table V4.1](#). If you are unsure which primary use your product falls into, please see the guidelines on [product eligibility](#).
 - If you are submitting the product as a "Specialty Use" product within a general application, please provide a short description of the types of applications the product is intended to be used for. Supplemental images provided with the application are often helpful to the DLC review staff in evaluating applications efficiently.
 - *DLC Category*: Select the Category you are submitting these products for consideration under. Please refer to the Technical Requirements Table if you are unsure.
 - *General Application*: Select the General Application you are submitting these products for consideration under. Please refer to the Technical Requirements Table if you are unsure.
 - *Primary Use*: Select the Primary Use designation are submitting these products for consideration under. Please refer to the Technical Requirements Table if you are unsure.
 - *Specialty Use Description*: If you are submitting the product as a "Specialty Use" product within a general application, please provide a short description of the types of applications the product is intended to be used for. Supplemental images provided with the application are often helpful to the DLC review staff in evaluating applications efficiently.
 - *DLC Classification*: Please indicate the classification you are submitting each product for consideration under in the Scaled Performance Table tab. This should be "Standard" or "Premium".
- d) **Section 4: Product Information**
- Please provide the requested information regarding the design and testing of your product.

- *Rated Voltage*: Enter the voltage range you market your product to operate on. E.g. 120-277V.
- *Driver Model Number*: Enter the model number for the driver you are using in your product. Please note that spec sheets must be included for DLC Premium applications, but are encouraged to be provided in all cases.
- *LED Package/Module/Array Part Number*: Enter the part number for the LED package/module/array you are using in your product. Please keep in mind that the DLC follows the [ENERGY STAR guidance](#) on LM-80 testing and evaluation.
- *LED Drive Current*: Enter the current at which you are driving your LEDs. If you are using a Chip-on-Board package/array in your product, please include both the drive current for the array and the calculated current-per-die.
- *Accessories*: If any additional accessories are employed in the testing of your product, please note those details in this field. Note that retrofit kits must be tested in a reference housing; the model number for that housing must be listed in this field.
- *Description*: Please enter a detailed description of your product or product group.
- *Controls*: Please indicate whether customers can order your product with integral sensors for occupancy sensing and photo control. DLC reviewers will verify these claims against information found in your spec sheet. This information is required for products seeking qualification in the DLC Premium classification, and optional for those in seeking qualification in the DLC Standard classification.
- *Housing Variations*: Please indicate whether your family group includes housing variations. Please note that the DLC Family Grouping policy currently allows for variations in size or dimension, but not shape. If your group does include housing variations, please include a brief description of each variation in the cells below. Important details include the size of each housing, and an indication of which model this housing is applicable to. The "A", "B", "C", etc. designations are indexing values that the DLC reviewer will use when evaluating your group and scaling methodology on the next tab.
- *Dimmability*: Please indicate whether or not this application includes products that are dimmable. Be sure to indicate the dimming performance of each product on the Scaled Performance Table tab.

e) **Section 5: Product Identifier Information**

- *Ordering Code/Model Number Information:* Enter a description of the character codes that make up your model number/ordering code. This description should be detailed enough for your DLC reviewer to understand what each character in your model number represents, and should be consistent with the information supplied in your spec sheet.

2. **Tab 2: "Scaled Performance Table"**

a) **Section 1: Scaling Methodology**

- Please explain the methodology used in developing the rated performance information for the products in this submission. This explanation should be sufficiently detailed to cover all variations within the product group, and for the DLC reviewer to be able to follow the engineering logic and development of any value in the table. Manufacturers may provide additional information on their scaling methodology in separate documents as necessary to communicate these details.

b) **Section 2: Performance Table**

- Please provide the information requested in each column for every product in the group you are submitting for application. Please include only those products you are submitting for application.
- *Primary/Specialty Use:* Please enter the Primary Use designation you are submitting these products for qualification under, consistent with the DLC Technical Requirements table. If you are submitting these products under the "Specialty" designation, please include "Specialty:" along with the name of the end-use application these products will be used in in the market place. For example, stadium lighting would be "Specialty: Stadium Lighting."
- *Classification:* Please enter the DLC classification you are seeking qualification for each product in: Premium or Standard. The requirements for each classification can be found on the Technical Requirements page.
- *System Type:* Please enter whether the product operates on an AC system or a DC or PoE system.
- *Minimum and Maximum Input Voltage:* Enter the voltage range for the product in these columns.
- *Model Number:* Please enter the complete model numbers for the products you are seeking qualification for in this column. Please note that model numbers must be complete model numbers, including all details to specify the

performance of the product. Wild-card characters may only be used to represent variations that do not affect performance, such as exterior housing color.

- *Scaled Initial Light Output*: Please enter the expected light output for the products in your group in this column. Rated data must be representative of the tested configuration of the products within the application. For Linear Replacement Lamps and Four Pin-Base Replacements for CFLs, the rated data must be representative of the bare lamp, including any ballast losses for Type A lamps. For Retrofit Kits and Mogul Screw-Base Replacements for HID Lamps, the rated data must be representative of the product tested in the appropriate reference housing. Please be sure that these values are traceable to the scaling methodology you describe.
- *Scaled Luminaire Efficacy (AC)*: Please enter the expected efficacy for the AC products in your group in this column. If the product is a DC/PoE product, leave this field blank. Rated data must be representative of the tested configuration of the products within the application. For Linear Replacement Lamps and Four Pin-Base Replacements for CFLs, the rated data must be representative of the bare lamp, including any ballast losses for Type A lamps. For Retrofit Kits and Mogul Screw-Base Replacements for HID Lamps, the rated data must be representative of the product tested in the appropriate reference housing. Please be sure that these values are traceable to the scaling methodology you describe.
- *Scaled Efficacy (DC)*: Please enter the expected efficacy for the DC products in your group in this column. If the product is an AC product, leave this field blank.
- *Scaled Input Power*: Please enter the expected power (wattage) for the products in your group in this column. Rated data must be representative of the tested configuration of the products within the application. For Linear Replacement Lamps and Four Pin-Base Replacements for CFLs, the rated data must be representative of the bare lamp, including any ballast losses for Type A lamps. For Retrofit Kits and Mogul Screw-Base Replacements for HID Lamps, the rated data must be representative of the product tested in the appropriate reference housing. Please be sure that these values are traceable to the scaling methodology you describe.
- *Scaled Total Harmonic Distortion*: Please enter the expected THD for the products in your group in this column. Rated

data must be representative of the tested configuration of the products within the application. For Linear Replacement Lamps and Four Pin-Base Replacements for CFLs, the rated data must be representative of the bare lamp, including any ballast losses for Type A lamps. For Retrofit Kits and Mogul Screw-Base Replacements for HID Lamps, the rated data must be representative of the product tested in the appropriate reference housing. Please be sure that these values are traceable to the scaling methodology you describe.

- *Scaled Power Factor*: Please enter the expected power factor for the products in your group in this column. Rated data must be representative of the tested configuration of the products within the application. For Linear Replacement Lamps and Four Pin-Base Replacements for CFLs, the rated data must be representative of the bare lamp, including any ballast losses for Type A lamps. For Retrofit Kits and Mogul Screw-Base Replacements for HID Lamps, the rated data must be representative of the product tested in the appropriate reference housing. Please be sure that these values are traceable to the scaling methodology you describe.
- *Scaled CCT*: Please enter the expected correlated color temperature (CCT) for the products in your group in this column. Rated data must be representative of the tested configuration of the products within the application. For Linear Replacement Lamps and Four Pin-Base Replacements for CFLs, the rated data must be representative of the bare lamp, including any ballast losses for Type A lamps. For Retrofit Kits and Mogul Screw-Base Replacements for HID Lamps, the rated data must be representative of the product tested in the appropriate reference housing. Please be sure that these values are traceable to the scaling methodology you describe.
- *Scaled CRI*: Please enter the expected color rendering index (CRI) for the products in your group in this column. Rated data must be representative of the tested configuration of the products within the application. For Linear Replacement Lamps and Four Pin-Base Replacements for CFLs, the rated data must be representative of the bare lamp, including any ballast losses for Type A lamps. For Retrofit Kits and Mogul Screw-Base Replacements for HID Lamps, the rated data must be representative of the product tested in the appropriate reference housing. Please be sure that these

values are traceable to the scaling methodology you describe.

- *Housing Variation*: This field is not needed for single product applications. If your product group includes housing variations, please see the Family Grouping rules.
- *Driver Model Number*: Please enter the driver model number(s) for the driver(s) used by each product in the application.
- *Vertical NEMA Beam Spread*: If you are seeking qualification for your product in one of the flood or spot Primary Use designations, please enter vertical NEMA Beam classification.
- *Horizontal NEMA Beam Spread*: If you are seeking qualification for your product in one of the flood or spot Primary Use designations, please enter horizontal NEMA Beam classification.
- *Base Type*: Enter the base type if the product is a linear replacement lamp or mogul-screw base product.
- *Sensors*: Please indicate whether your products can be ordered with integral occupancy sensors or photocontrols. This field must be filled out for products seeking qualification in the DLC Premium classification, and is optional for products in the DLC Standard classification.
- *Dimming Capability*: Please indicate whether your product is dimmable. If the product is dimmable, fill out the dimming type, minimum dimming level, default light output, and default wattage in the columns that follow.
- *Dimming Type*: If your product is dimmable, please indicate whether it dims in a continuous or stepped manner.
- *Minimum Dimming Level*: If your product dims continuously, please indicate whether it can dim to $\leq 10\%$ of its full input power. Please note this question is about the power consumed by the product in the dimmed state, not the light output.
- *Field Adjustable Light Output*: Mark whether the product is capable of adjusting the light output in the field. If the product is field adjustable, enter the default light output, default wattage, minimum wattage, minimum light output, and maximum light output in the subsequent columns.
- *Length*: If you are seeking qualification for your product in one of the screw-base replacements for HID lamps, linear ambient, or display case luminaires Primary Use designation, please enter the length of the product in inches.
- *Rf*: If you wish to provide information about the product's Fidelity Index (Rf) according to TM-30, please indicate the

value here. This metric is currently optional, and not required for listing. To list this metric for products on the QPL, you must use the official Excel version of the TM-30 calculation tool offered with the IES standard.

- *Rg*: If you wish to provide information about the product's Gamut Index (Rg) according to TM-30, please indicate the value here. This metric is currently optional, and not required for listing. To list this metric for products on the QPL, you must use the official Excel version of the TM-30 calculation tool offered with the IES standard.
- *Safety Organization and File Number*: Please enter the organization under which the products are safety certified and the file number for the certification document
- *White Tunable*: Mark whether the product is white tunable. If the product is white tunable, enter the minimum CCT, maximum CCT, maximum wattage, and minimum wattage in the subsequent columns.
- *Dim-to-Warm*: Enter Yes or No to specify whether the product can dim-to-warm.

IV. **Dimming Policy**

DLC members have expressed a need to be able to identify products that are able to dim with certain characteristics. The DLC collects and reports specific dimming information to accommodate this need.

Dimming Information to be Collected and Reported

As of November 2018, DLC began collecting and reporting the following information for all new products:

Please report the following information when completing the Product Application Form:

- *Dimming Capability*: Please indicate whether your product is dimmable.
- *Dimming Type*: If your product is dimmable, please indicate whether it dims in a continuous or stepped manner.
- *Minimum Dimming Level*: If your product dims continuously, please indicate whether it can dim to $\leq 10\%$ of its full input power. Please note this question is about the power consumed by the product in the dimmed state, not the light output.
- *Default Light Output and Default Wattage*: If the product is dimmable or capable of field adjustable light output, please fill out the default light output and wattage.

Due to the lack of an industry standard testing methodology to verify dimming capability and performance under dimmed conditions, DLC will not require testing be submitted to verify dimming performance at this time. The DLC will monitor industry progress toward standard testing methodology and determine if performance

information should be reported and/or performance requirements be instituted in the future.

Beginning July 2014, qualified product's dimming capability will be indicated as "Not Yet Verified" unless or until dimming information is provided.

Supporting Documentation

For all new products submitted for qualification, manufacturers will be required to self-report a product's dimming capability, dimming type, and whether the product is capable of dimming continuously to 10% or below its full input power. Manufacturers must identify the unique model number(s) for each product variation submitted in an application with different combinations of reported dimming information. Products with different performance with respect to these three dimming characteristics will not be permitted to be represented by the same model number listing on the QPL.

The DLC will evaluate a manufacturer's claims of dimming capability by ensuring that the dimming claims are clearly published in the product specification sheet and correspond with the unique model numbers submitted. The DLC will also evaluate the manufacturers' product installation instructions, including any supporting commissioning manuals, to determine eligibility. The installation instructions must be the same ones provided to customers and installers in the market. DLC reviewers may check web listings and other marketing materials and reserve the right to request additional information to demonstrate dimming capability if information in product specification sheets is not sufficient.

Application Fees

Update Applications

Due to the need for DLC staff to review and process product updates, there will be a cost for relisting products with appropriate dimming information and field adjustable capability.

For applications to update products already on the QPL, there will be an update application fee per family group submitted, based on the number of products within each family group. The table below details the per-family application fee for various numbers of products within each group. Note that the size of the family group below is based on the total number of products, including any additional models needing to be listed to differentiate dimming or field adjustable capabilities.

Total Number of Products in the Updated Family Group	Fee to Update Family
1-10	\$260.00
11-100	\$365.00
101-500	\$445.00

501-1000	\$520.00
1001-2500	\$625.00
2501+	\$675.00

Manufacturers may submit multiple families within one dimming update application.

New Applications

For applications of new products going forward, additional listings necessary to distinguish between product variations with differing performance on the dimming characteristics above will need to be identified. For single product submissions, dimming variations will be allowed, along with CCT variations, with no additional application fees.

For family grouping applications, the regular additional family member fee of \$25 per product will continue to apply to the number of listings necessary prior to the implementation of the dimming policy, consistent with the existing fee structure. For additional products necessary to be listed ONLY to identify the differing dimming performance, manufacturers will either be required to pay the \$25 per product fee, or the fee based on the chart above, whichever amounts to the lower total application fee.

V. Manufacturer Name Updates

The DLC understands that manufacturer names may go through changes after establishing an account with the DLC. To ensure that reviewers have the necessary documentation to accurately evaluate applications and that information listed on the QPL is consistent, the DLC will require the following for any manufacturer who wishes to change its manufacturer name after establishing a DLC account:

- Government issued documentation demonstrating the change in company name. The documentation must be issued by the jurisdiction under which the company operates. Reviewers reserve the right to ask for additional documentation if the information provided does not appear to be official government issued documentation.
- Manufacturers will be restricted to changing company names only one time per year. The DLC will allow exceptions to this rule for companies that are bought/sold multiple times within the same year. In the event that a company is bought/sold multiple times within the same year and requires more than one name change within the same year, the DLC will ask for sufficient documentation to demonstrate the need for multiple name changes.
- Application documentation must represent the new company name within 3 months of the company name change documentation being approved by the DLC. After this 3 month grace period, any documentation submitted representing the previous company name will be asked to be revised in order to move forward with the application.

I. Frequently Asked Questions

The FAQs address common questions and note technical interpretations followed by the DLC program. FAQs are updated regularly to reflect the most up-to-date policies used to review an application. Manufacturers should read the FAQ page prior to each submission to ensure they are familiar with current policies. To access the FAQ page, click [here](#).

II. DLC Qualified Products List

When a product or group of products passes DLC qualification, the product(s) are added to the DLC Qualified Products List (QPL). The QPL provides a centralized list of high-performing, verified, and tested LED products. The QPL helps DLC members determine which products may be eligible for incentive or rebate programs. While its members pledge to use the DLC QPL to make informed decisions about eligibility for rebates and incentives, the DLC does not have control over the rebate and incentive distributions; these decisions are at the sole discretion of the members. A product listed on the DLC QPL will not automatically receive rebates or incentives.

DLC publishes manufacturer and model identifying information, as well as verified worst case tested performance or reported performance information for each product.

These fields include:

- Manufacturer
- Brand
- Model Number
- Qualification Date
- Listing Status (Listed or Delisted)
- Technical Requirement Version
- General Application type
- Primary Use type
- DLC Classification Type (Standard or Premium)
- Electrical System Type (AC/DC)
- Luminaire Efficacy
 - Luminaire efficacy should be reported as the total luminous flux from the fixture divided by the total input power. Luminous flux is based on the photopic luminous efficiency function (V_{λ}), not scotopic or mesopic efficiency.
- Light Output (lumens)
- Power Factor and Total Harmonic Distortion (THD)
- Correlated Color Temperature (CCT)
- Color Rendering Index (CRI)
- Wattage
- Light Distributions (i.e., zonal lumen density, NEMA classification, and/or spacing criteria)
- Input Voltage Range -Parent only
- Dimming Information (reported)
- Control Info (reported)
- Parent or child designation
 - Parent products display tested and reported data and are displayed on a green tile

- Child products display reported data, are listed under each associated parent product, and are displayed on a gold tile
- Private label versions of products display exactly the same performance information as their OEM versions.

No two model numbers can be listed under the same product category on the QPL for one given manufacturer. If a manufacturer submits the same model number for multiple products, the DLC reviewer will insist the manufacturer make some distinction in the model numbers that represent the variations of the product. The utility and consumer must be able to identify the differences between products from the model number listed on the QPL.

The QPL is a database that is automatically updated each time a product is entered. Users of the QPL should be aware that only model numbers found in the database are considered DLC qualified. Please contact the DLC inbox at applications@designlights.org if you cannot find on the QPL a product that you believe has been qualified.

De-Listed Products

As the DLC goes through specification revision processes, currently qualified products are required to be compliant with the effective Technical Requirements at the end of the designated grace periods. Products that are removed from the QPL due to no longer meeting the Technical Requirements are still searchable through the database. Users have the option to select a check-box to include de-listed products in a product search.

A manufacturer may request to have their listed products delisted from the QPL by emailing applications@designlights.org. To request products to be delisted, please provide the following:

- An QPL download (Excel file format) of the products to be delisted
- A signed statement on company letterhead requesting the products be delisted

When submitting a delisting request, please be aware that when OEM products are delisted, their corresponding Private Label products will also be delisted. All associated Private Labelers will be informed if their products are also delisted, with a message instructing the Private Labeler to reach out to their OEM for additional information regarding this delisting. Additionally please note that child products cannot be listed in on the QPL without a bracketing Parent product. If delisting all Parent products of the original family, please include all associated child products in QPL download. Please note that unique guidance exists for products selected for Surveillance Testing. Manufacturers of products selected for Surveillance Testing should contact surveillance@designlights.org.

III. Logo Guidelines

Once a product or group of products is qualified, manufacturers may market that specific product or group of products as DLC qualified. Before including reference to DLC qualification in any marketing materials, please review the following DLC Logo Guidelines. Additional detail can be found on the DLC [Logo Guidelines web page](#).

DLC also uses and protects the trademark “DesignLights Consortium” and “DLC.” The DLC Logos, as well as the trademark “DesignLights Consortium” and “DLC” are all either pending applications or registered with the US Patent and Trademark Office. These trademarks help make the DLC identity a valuable asset, and like any asset with appreciable value, the trademarks must be properly used and protected.

The DLC Logos and trademarks are not only a valuable asset to the DLC, but equally valuable to all members and product manufacturers who qualify. In order to retain that value, all stakeholders must use the DLC Logos and trademarks consistently and in compliance with these Guidelines in all communication and outreach materials. Ensuring that the DLC Logos and Trademarks are properly used protects every DLC stakeholder’s investment in the program—and consumer confidence in the DLC brand.

Authorized Use of the DLC Logos and Trademarks

As a general rule, third parties (i.e., anyone other than the DLC and those granted explicit permission by the DLC) are not allowed to use the DLC Logos without permission. The purpose of the DLC Logo and Trademark Use Guidelines is to provide clarification about how the DLC Logos and Trademarks should be used by its stakeholders. The DLC Logos must always be used pursuant to the specifications in these Guidelines to identify the DLC or participation in the DLC program. Any use that falls outside of these specifications is strictly prohibited.

Participants in the DLC program agree to the DLC Logo and Trademark Use Guidelines and all DLC rules and policies, which may be updated at any time. Participants must acknowledge that the DLC (through Efficiency Forward, Inc.) is the sole owner of the DLC Logos and Trademarks, and agree not to interfere with the DLC’s rights in them, and acknowledge that goodwill derived from their use accrues only to the DLC. The DLC will review stakeholder’s use of the DLC Logos and Trademarks on a number of materials, including specifications sheets, website, and other marketing materials. The DLC reserves the right to request modification for any non-compliant use as well as terminate participation in the DLC program for continuous violations of the Guidelines.

The DLC Logos and Trademarks and authorized participation are as follows:

I. DLC Program Logo



Used by DLC members: To indicate membership on web pages of their energy efficiency programs.

** DLC members are regional, state, utility, and energy efficiency programs throughout the U.S. and Canada*

Lighting Testing Laboratories: To indicate available product testing services necessary for manufacturers to submit an application. NOTE: Laboratories must meet the DLC accreditation requirements to display the logo. The DesignLights Consortium name and marks may not be displayed in test reports or be used in a manner that implies DLC endorsement of a laboratory or its services, only that those services are provided to manufacturers

Manufacturers and Distributors

May not use the Program Logo without explicit permission by the DLC.

Other: Additional use of the DLC program logo will be assessed on a case-by-case basis. Please contact info@designlights.org.

- The DLC Program Logo may not be altered, cut apart, separated, or otherwise distorted in perspective or appearance.
- The preferred color for the DesignLights Consortium mark is black for the text and yellow for the graphic. Alternate versions are available – such as colors being reversed out to white with yellow graphic are allowed. PLEASE refer to the style guide for information on the Standard and Alternative ways to use the DLC Program Logo.
- The DLC Program Logo must be large enough so that the lettering inside the logo is clearly legible in all mediums.
- The DLC Program Logo must be clear within “C” space of logo elements from all sides.
- The DLC Program Logo size should never be under 1.72 inches wide and .45 inches high to maintain legibility.

Common Mistakes to Avoid

- Do NOT reproduce the DLC Program Logo smaller than 1.72 inches (width) and .45 inches (height).
- Do NOT use the DLC Program Logo to indicate DLC Qualification of a product; see below for qualification usage.
- Do NOT copy the DLC Program Logo from the internet; please contact info@designlights.org for the official image files.

For further instructions on the use of the DLC Program logo, please review the [DLC Program Logo Style Guide](#).

II. DLC QPL Product Logo



III. DLC QPL Premium Logo



The following guidelines apply to the use of both the DLC QPL Product Logo and the DLC QPL Premium Logo ("DLC QPL Logos"). Whereas the DLC QPL Product Logo may be used for both qualified luminaires and qualified networked lighting controls systems, the DLC QPL Premium Logo is not applicable to the controls systems.

For Use By:

Manufacturers and Distributors (including private labelers)

To indicate that certain products have been DLC qualified and are listed on the QPL.

NOTE: Use may be of the DLC QPL Product and Premium Logo (pictured above), or Approved Terminology, such as (1) "Product X is a DesignLights Consortium qualified product;" (2) "Product Y is listed on the DLC QPL;" or (3) underneath the product, indicate "DesignLights Consortium Qualified luminaire/system" or "a luminaire/system that is listed on the DesignLights Consortium Qualified Products List."

Used by Manufacturers and Distributors: To indicate that certain products are listed on the DLC QPL and meet the technical requirements of the DLC Premium Classification. [View](#) for the technical requirements for the DLC Premium Classification.

Guidelines for Use of the DLC QPL Product and DLC QPL Premium Logos

- The DLC QPL Logos may not be altered, cut apart, separated, or otherwise distorted in perspective or appearance.
- The preferred color for the DLC QPL Logos is black and yellow. Similar to above, there are alternative formats available. Please refer to [the style guide](#) for information on the Standard and Alternative ways to use the DLC QPL Logos.
- The DLC QPL Logos must be large enough so that the lettering inside the logo is clearly legible in all mediums.
- The DLC QPL Logos must be clear within "C" space of logo elements from all sides.
- The DLC QPL Logos should never be under .5 inches wide and .5 inches high to maintain legibility.

Use of the Logos on General Marketing Materials

General Marketing Materials are defined as Website Home Pages and General Information Pages such as About Us Pages, Covers of Brochures and Catalogs, Tradeshow Booth Displays - not in reference to specific products.

- A pre-requisite for use of the DLC QPL Logos on general marketing materials is that the user in question must have products listed on the DLC QPL under the appropriate classification, or else the user must cease use of the DLC Product and Premium Logos immediately.
- The DLC QPL Logos may be used on general marketing materials to indicate the user has products listed on the QPL without reference to the exact model numbers that appear on the QPL.

Use of the Logo on Product-Specific Marketing Materials

- The DLC QPL Logos or Approved Terminology may only be used in association with specific products or control systems that have been verified to meet the technical requirements of the DesignLights Consortium and which appear on the DLC QPL.
 - The DLC Premium logo may only be used in association with products that have been verified to meet the technical requirements of the DLC Premium classification and which appear on the DLC QPL.
- In order to use the DLC QPL Logos for Solid State Lighting products, the user must provide the exact model numbers or DLC Product Codes on the marketing material.
 - This information will allow the reader to locate the identified product on the most current version of the DesignLights Consortium Qualified Products List without further aid.
 - If not all products on the specific marketing materials are qualified, the user must indicate so in a clear manner so that the reader can easily determine which products are listed.
 - If a product was not qualified under all Primary Use Designations or applications that it is sold and marketed under, the user may only claim DLC qualification or use the DLC QPL Logos in reference to the Primary Use Designation or application under which a product was qualified.
- In order to use the DLC QPL Logos for Networked Lighting Control systems, the user must provide the qualified system name on the marketing material as it is listed on the Networked Lighting Control QPL.
- Products or control systems which have not yet been qualified should under no circumstances display the DLC QPL Logos.
- Users who sell but do not manufacture products or systems listed on the DLC QPL (e.g. distributors) must include the name of the manufacturer and manufacturer's model number(s) prominently and in proximity to DLC QPL Logos. Organizations

who use their own name and model number in any form to market products must submit a [private label application](#).

- Manufacturers are responsible for ensuring that they, as well as any of their distributors and private labelers, use the correct model number on qualified products and that the DLC QPL Logos are being properly used on websites and specification sheets and materials.
 - Manufacturers must list their products on the DLC QPL under any and all brand names under which they are marketed and sold – even the ones that are private labeled.
 - To ease the process of re-listing qualified products under alternate brand names, please consult the [Private Labeling/Multiple Listing Policy](#).

Common Mistakes to Avoid

- Do NOT remove any of the wording, such as DLC, QPL, LISTED, or PREMIUM from the DLC QPL Premium Logo.
- Do NOT reproduce the DLC QPL Premium Logo smaller than .5 inches (width) and .5 inches (height).
- Do NOT use the DLC QPL Premium Logo to indicate membership in the DesignLights Consortium.
- Do NOT use multiple model numbers for your premium qualified products; the model number that is listed under the DLC Solid State Lighting Qualified Products List Premium Classification MUST match the model number used by manufacturers and distributors on websites and specification sheets and materials.
- Do NOT use the DLC logos or claim DLC qualification in association with product applications or Primary Use Designations under which the product model numbers were not qualified.
- Do NOT use the DLC logos or claim DLC qualification in association with product applications or Primary Use Designations that do not exist.
- Do NOT place the DLC QPL Product logo directly on your product or product packaging. No matter what your status of qualification. The logos are intended for use on websites and marketing materials only.
- Do NOT copy the DLC QPL Product Logo, or the DLC QPL Premium Logo from the internet; please contact info@designlights.org for the official image files.
 - NOTE: Specific model numbers should be included in all requests for DLC QPL Logos files.
- Do NOT use the DLC QPL Logos on non-DLC qualified products.
 - This includes products that are marketed by the same manufacturer or under the same brand name.
- Do NOT use the DLC QPL Premium Logo for products that are NOT qualified as PREMIUM products.

- This includes products that are qualified products on the QPL, but not qualified as PREMIUM products on the QPL.
- Do NOT use any of the DLC QPL Logos in any other company name, product name, service name, domain name, or website title.
- Do NOT place the DLC QPL Logos in e-mail signature blocks or business cards.
- Do NOT use the DLC QPL Logos to imply DLC endorsement of a company, product, or service.
- Do NOT use any logo that is not listed above to indicate DLC qualification or DLC QPL listing of a product.

For further instructions on the use of the DLC QPL Logos, please review the [DLC QPL Product Logo Style Guide](#) and the [DLC QPL Premium Logo Style Guide](#).

IV. The Trademarks

DesignLights Consortium® and DLC®

For Use By:

DLC Members*, Manufacturers, Distributors and other third parties

To reference the DesignLights Consortium on websites and marketing materials.

** DLC Members are regional, state, utility, and energy efficiency programs throughout U.S. and Canada*

Guidelines for Use of the Trademarks

The trademark symbol ® must be used the first time the words DesignLights Consortium or DLC appear in any written material in the following manner:

- The ® symbol should always be in superscript;
- There should be no space between DesignLights Consortium and the ® symbol;
- The ® symbol should be repeated in a document for each chapter title and in the first instance on each new web page.
- Do NOT alter the capitalization or spacing for DesignLights Consortium; the trademark should always appear as two words; the D, L and C should be capitalized and there should be no space between the terms DESIGN and LIGHTS.

Common Mistakes to Avoid

- Do NOT include "DLC" or "DesignLights Consortium" in your product or company name.
- Do NOT include "DLC" or "DesignLights Consortium" in your product model number.
- Do NOT place the "DLC" or "DesignLights Consortium" trademarks directly on your product or product packaging, regardless of the status of qualification. The trademarks are intended for use on websites and marketing materials only.

- Do NOT use the “DLC” or “DesignLights Consortium” trademarks on non-DLC qualified products.
- This includes products that are marketed by the same manufacturer or under the same brand name.
- Do NOT use the “DLC” or “DesignLights Consortium” trademarks in any other company name, product name, service name, domain name, or website title.
- Do NOT use any trademark that is not listed above to indicate DLC qualification or DLC QPL listing of a product.
- Do NOT use the “DLC” or “DesignLights Consortium” trademarks to imply a DLC endorsement of a company, product, or services.
- Do NOT use the “DLC” or “DesignLights Consortium” trademarks in webpage tabs or URLs/webpage addresses.

Unauthorized/Improper Use

Unauthorized and/or improper use of the DLC Logos and Trademarks causes confusion among consumers, which results in tarnishment of the brand and its reputation. It may also constitute trademark infringement, trademark dilution, false advertising, fraud and/or other violations of law. The DesignLights Consortium actively monitors the use of the DLC Logos and Trademarks, but also requests the assistance of its stakeholders to help police its brand. To report a trademark violation or to ask for a review of materials, please contact info@designlights.org.

Upon discovery of a DLC Logo or Trademark violation by a manufacturer or distributor, the DLC will take the necessary steps to have that violation corrected as quickly as possible in order to minimize the damage. The DLC expects that all stakeholders will endeavor to be compliant with these Guidelines and will make all changes requested by the DLC in order to achieve compliance.

Violations of Logo Guidelines

In case of DLC Logo and Trademark misuse, the DLC reserves the right to suspend the user’s program privileges for up to 18 months. This may include a suspension (de-listing) of all currently qualified products, as well as an inability to qualify additional products during the suspension. The DLC will notify the user of the violation and consequences.

In addition to suspension and/or de-listing of products, the DLC reserves the right to charge a fee to cover legal expenses of the DLC trademark compliance program. Such a fee may start at \$250 per violation, depending on the severity of the infringement.

Conclusion

The DLC encourages the use of the logos and trademarks under the appropriate applications as documented in these Guidelines. Participants in the DLC Program must comply with the DLC Logo and Trademark Use Guidelines and all DLC rules and policies, which may be updated at any time. The DLC is the sole owner of the DLC logos and trademarks and actively monitors and takes action against violations of the DLC Logo and Trademark Use Guidelines and DLC policies.